

# ALBANY PARK

A COZY HOME BEGINS HERE

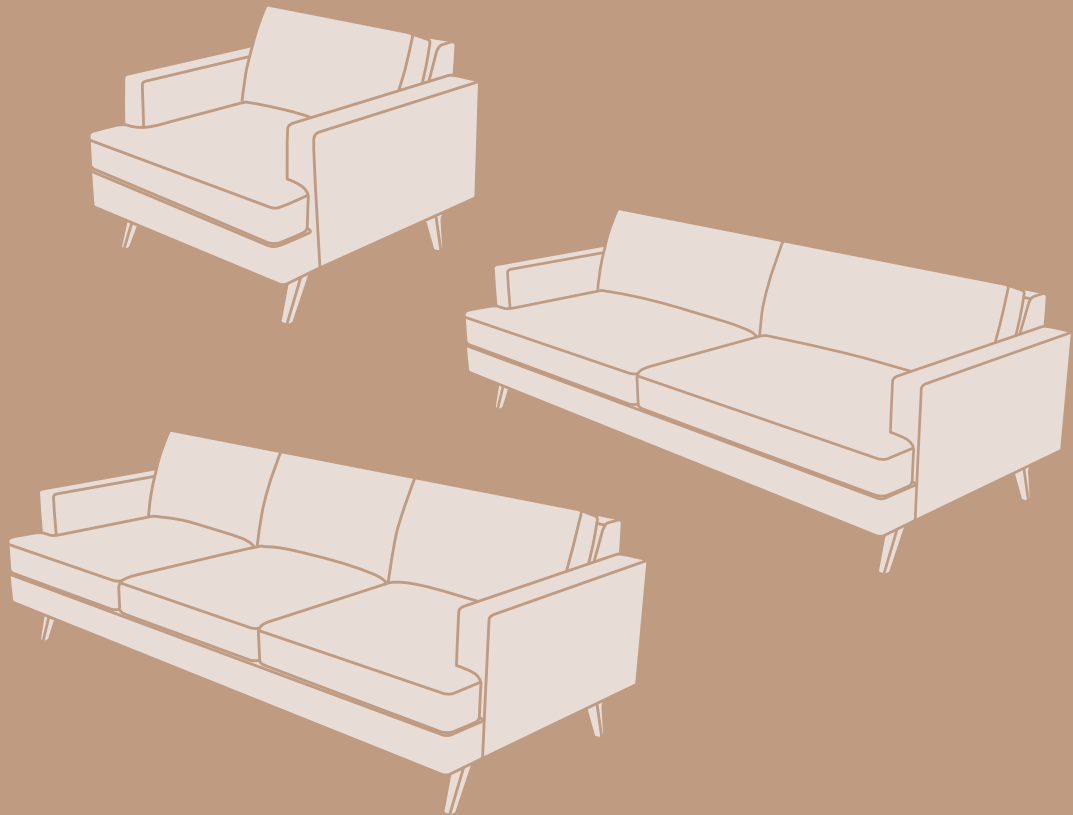

Lido Assembly Instructions

## Video Available

SEE HOW IT'S DONE  
Scan the QR code to  
watch the assembly video.

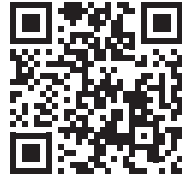

## Parts

Quantity of cushions varies by model.

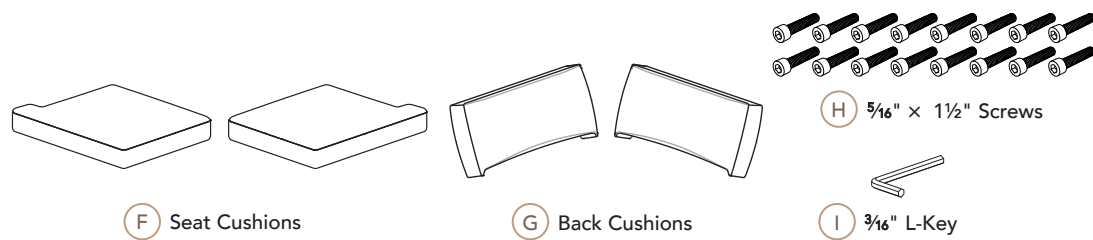
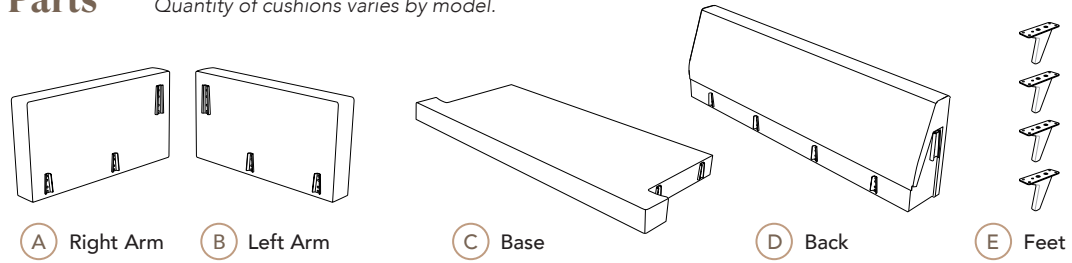

CONNECTING THE SOFA PARTS  
The brackets nest together like this...

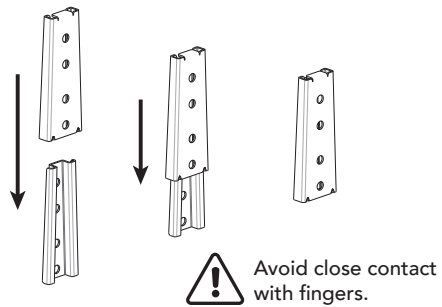

1. Attach the right arm to the base.

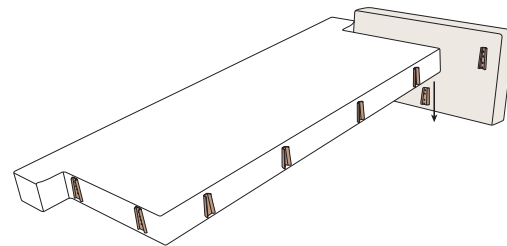

2. Attach the left arm to the base.

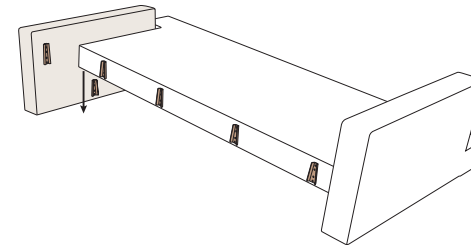

3. Attach the back to the base.

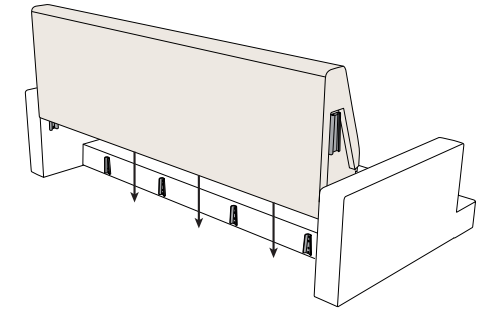

4. Lean the assembly onto its back and prop the bottom edge up with small blocks or boxes.

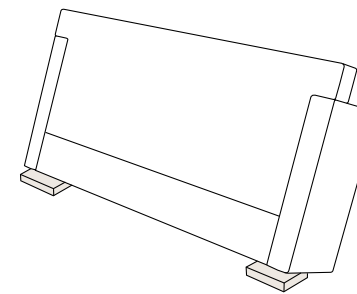

5. Make sure the bends of the feet face inward and attach them using the provided L-key.

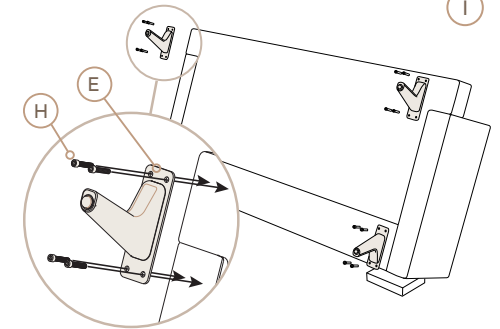

6. Settle the seat cushions onto the base.

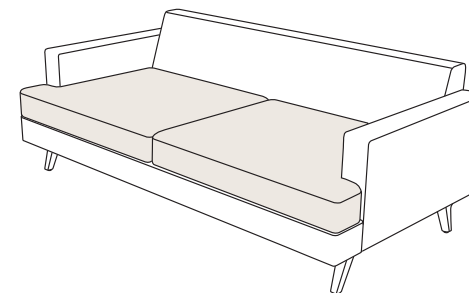

7. Nestle the back cushions against the back.

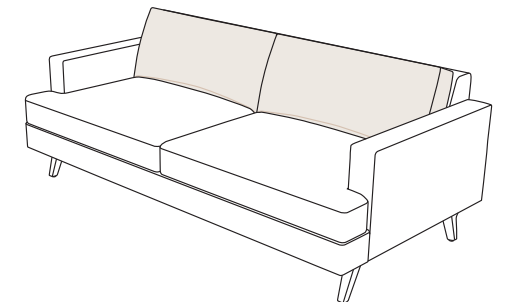



# MAVIX

## MONITOR ARM

When you're hard at work, you need a workspace that works hard for you. With a wide range of motion and ultra-reliability, the Mavix monitor arm is your go-to solution to maximize your space. Its compact design and die cast aluminum construction mean greater stability, flexibility and unmatched performance.

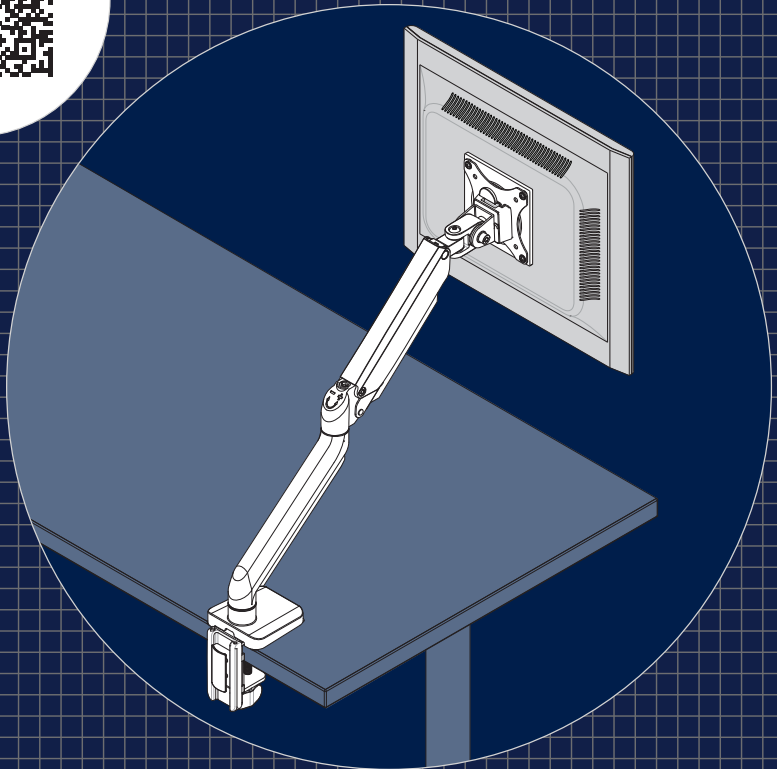

# MONITOR ARM ASSEMBLY INSTRUCTIONS

Read the entire instruction manual before you start installation and assembly. If you have any questions regarding any of the instructions or warnings, please contact your local distributor for assistance.

To report any issues with this product, contact our customer experience team at: (833) 628-4944 or [service@mavix.com](mailto:service@mavix.com).

## WARNING

### RISK OF DEATH AND SERIOUS INJURY

Monitor arms are not intended for applications where the monitor arm extends beyond the perimeter of the worksurface.

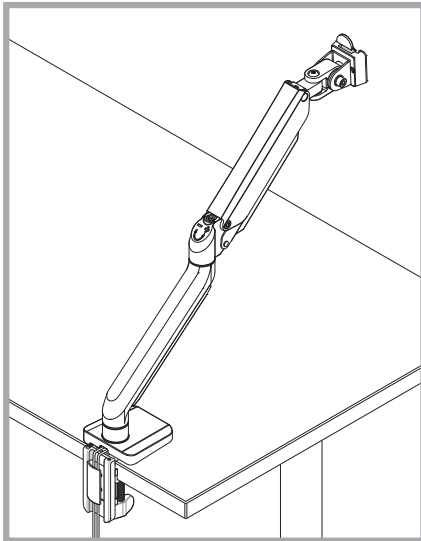

Correct

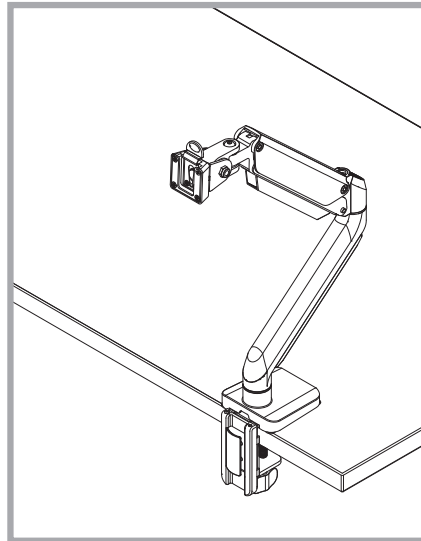

Incorrect

# MONITOR ARM ASSEMBLY INSTRUCTIONS

## Recommended Tools

- 4 mm Hex Key (Included)
- 6 mm Hex Key (Included)
- Open Ended Wrench (Included)
- #2 Phillips Screwdriver

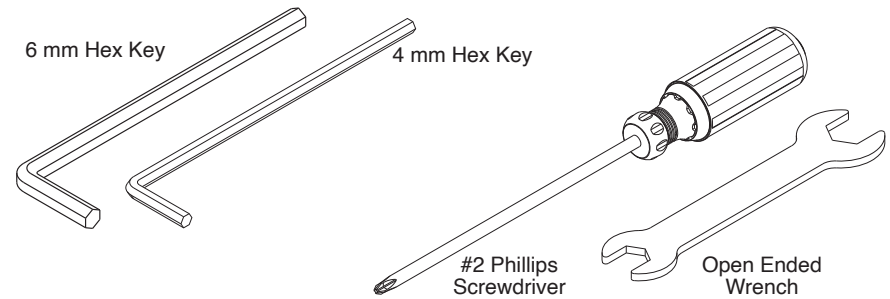

# MONITOR ARM ASSEMBLY INSTRUCTIONS

# MONITOR ARM ASSEMBLY INSTRUCTIONS

## Parts: Single Monitor Arm

- Single Desk Monitor Arm (1)
- Upper Bracket (1)
- Bottom Bracket (1)
- Cable Clamp Cover (1)
- Monitor Arm (1)
- VESA Plate (1)

### Hardware Kit

- M4 x 12 mm Screw (4)
- M5 x 12 mm Screw (4)
- M5 Flat Washer (4)
- M6 x 12 mm Screw (3)

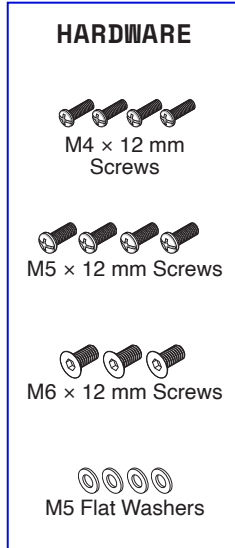
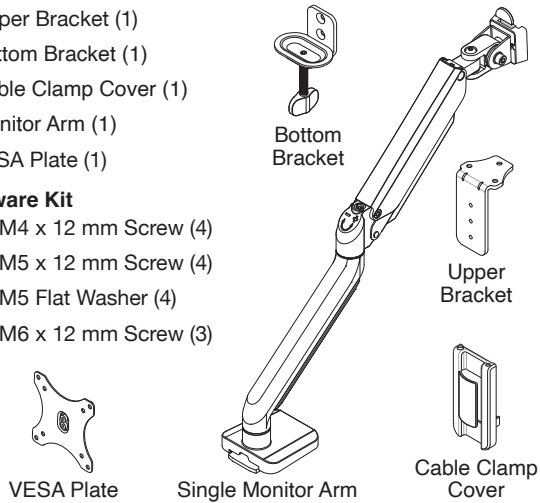

## Parts: Bolt-through/grommet style installation (single arm)

- Upper Mounting Plate (1)
- Lower Mounting Plate (1)
- Hardware Kit
  - M8 x 105 mm Carriage Bolt (1)
  - M8 Lock Washer (1)
  - M8 Hex Nut

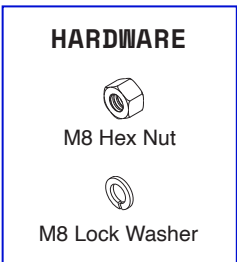
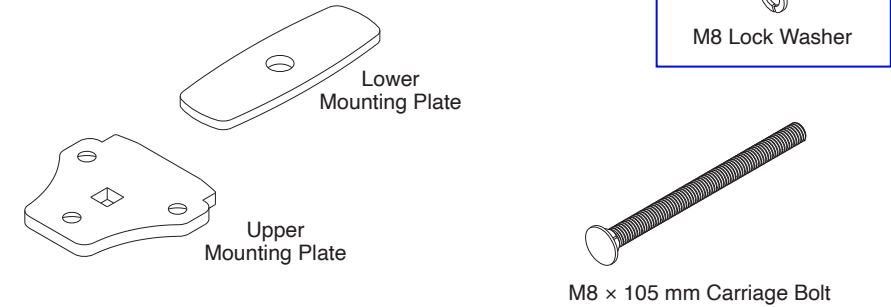

## Parts: Dual Monitor Arm

- Dual Desk Monitor Arm (1)
- Upper Bracket (1)
- Bottom Bracket (1)
- Cable Clamp Cover (1)
- Monitor Arm (1)
- VESA Plate (2)

### Hardware Kit

- M4 x 12 mm Screw (8)
- M5 x 12 mm Screw (8)
- M5 Flat Washer (8)
- M6 x 12 mm Screw (3)

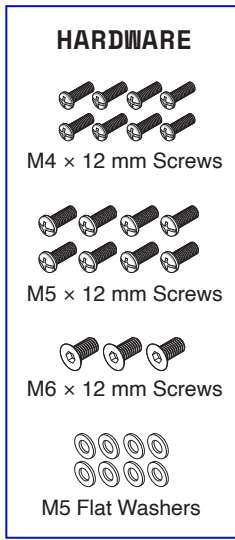
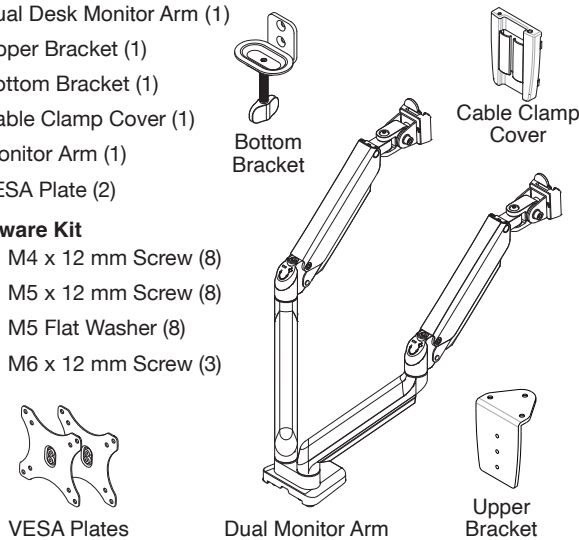

## Parts: Bolt-through/grommet style installation (dual arm)

- Upper Mounting Plate (1)
- Lower Mounting Plate (1)
- Hardware Kit
  - M8 x 105 mm Carriage Bolt (1)
  - M8 Lock Washer (1)
  - M8 Hex Nut

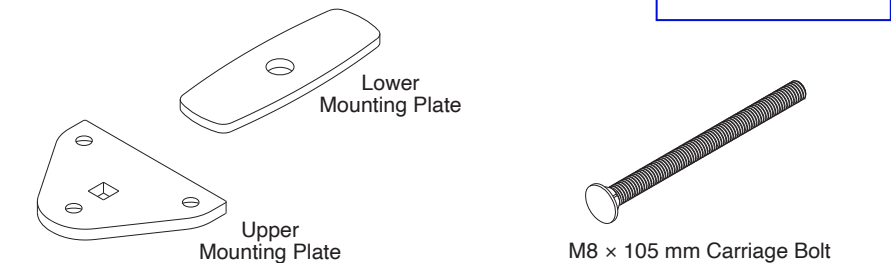



# MONITOR ARM ASSEMBLY INSTRUCTIONS

**Edge Mount Step 1:** Attach the upper bracket to the monitor arm's base.

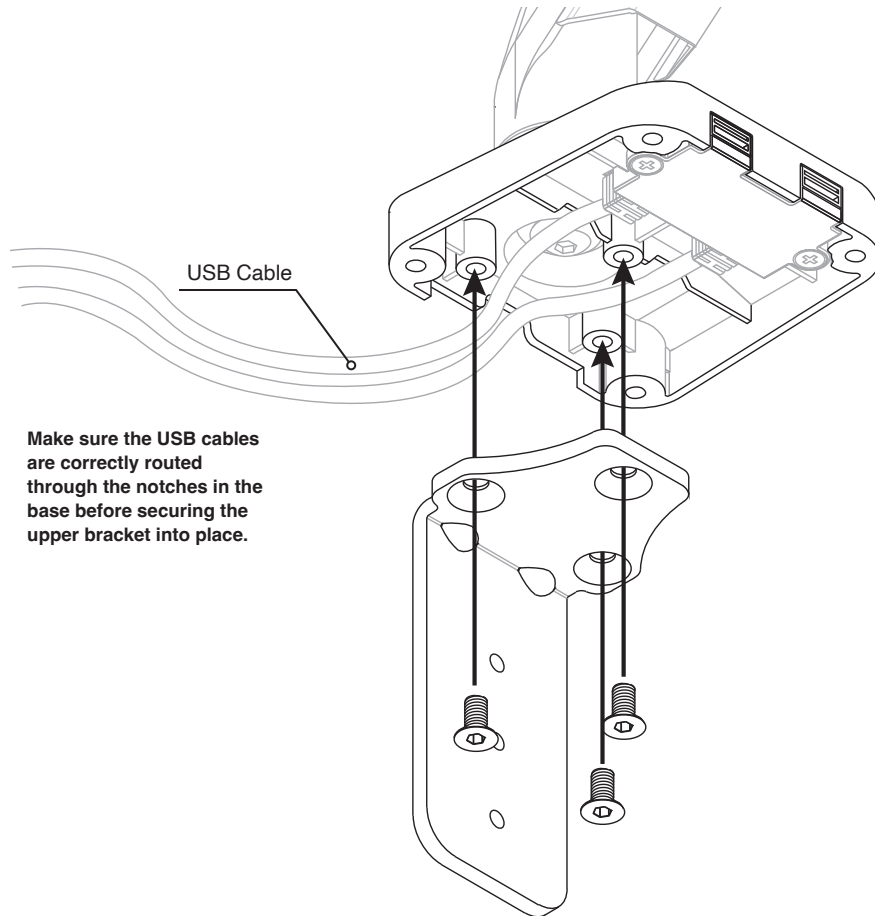
See page 12 for grommet-mount instructions or page 17 to install against a wall.

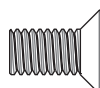

<b>1:1 HARDWARE</b>	<b>TOOLS</b>
	
M6 x 12 mm Screw	4 mm Hex Key



# MONITOR ARM ASSEMBLY INSTRUCTIONS

**Edge Mount Step 2:** Peel the backing off the protective pads and adhere them to the monitor arm base.

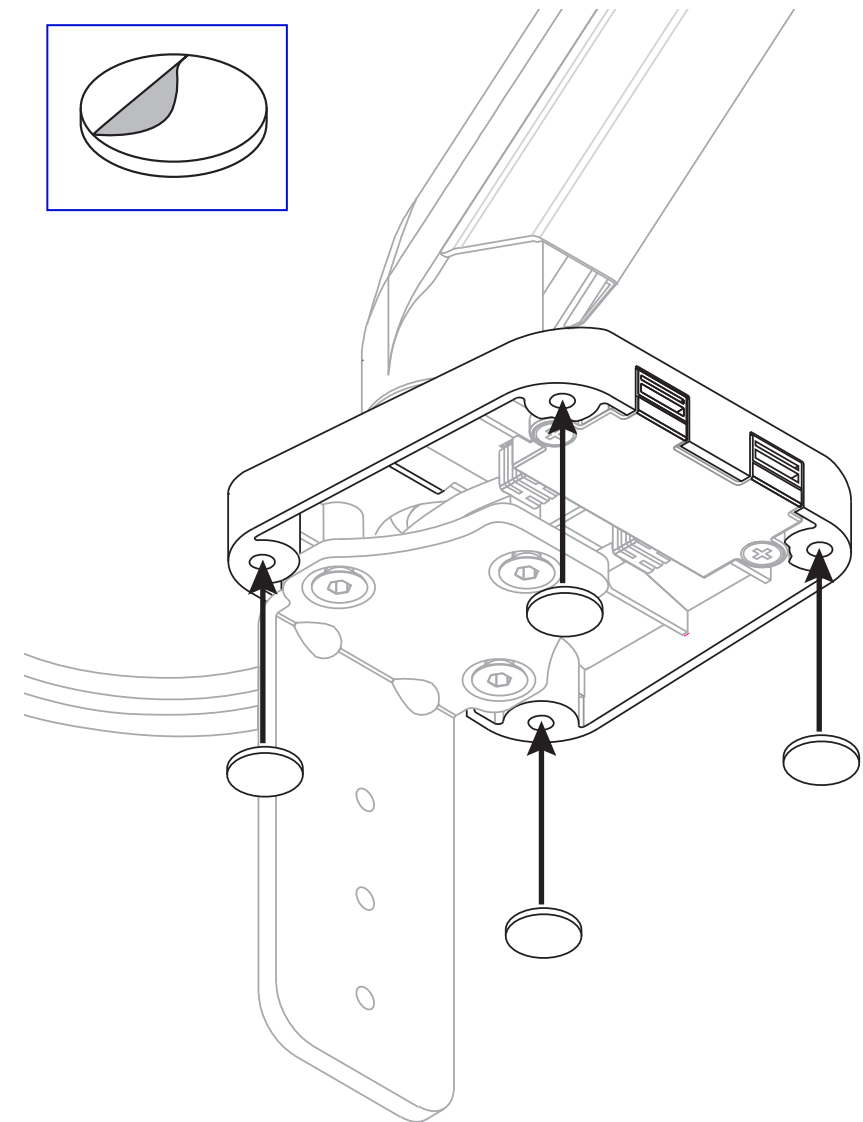

# MONITOR ARM ASSEMBLY INSTRUCTIONS

## Edge Mount Step 3: Attach bottom bracket.

This assembly is compatible with 0.5"–2.5" thick tabletops.

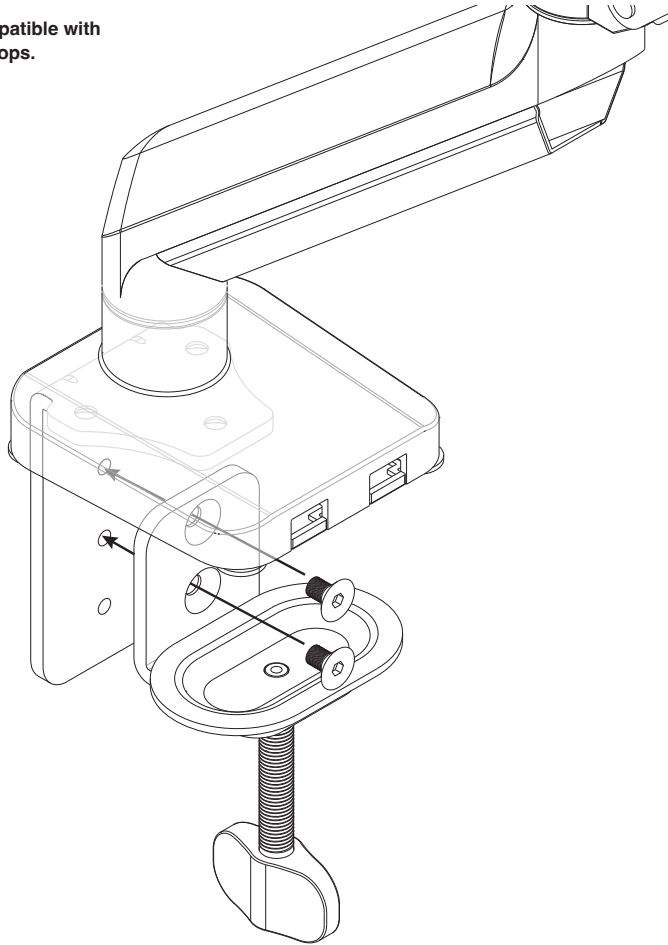

### 1:1 HARDWARE

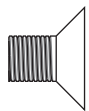

M6 x 10 mm Screw

### TOOLS



4 mm Hex Key

# MONITOR ARM ASSEMBLY INSTRUCTIONS

## Edge Mount Step 4: Snap the cable clamp cover to the cable clamp.

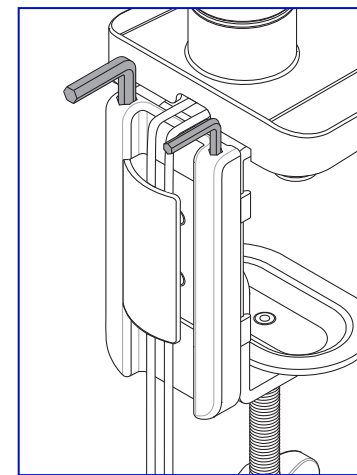

Cable cover clamp includes a place to store the provided hex keys.

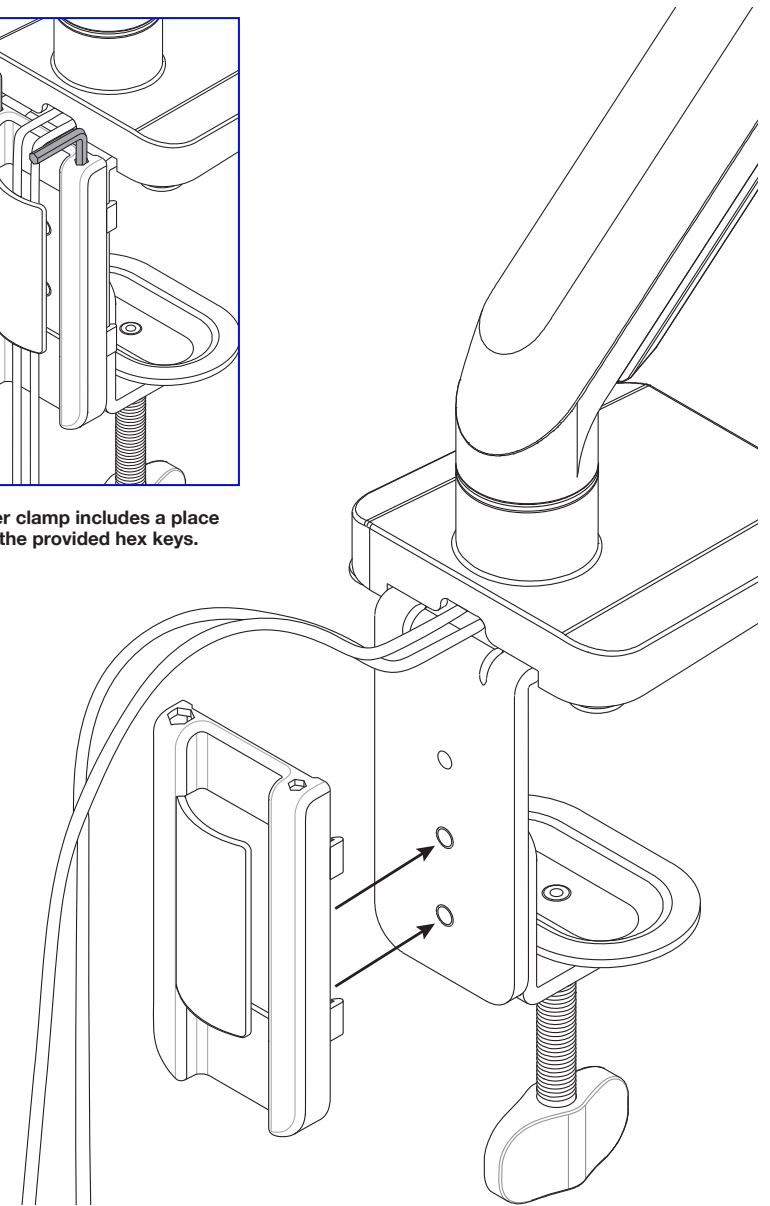

## MONITOR ARM ASSEMBLY INSTRUCTIONS

**Edge Mount Step 5:** Slide the monitor arm onto the tabletop.

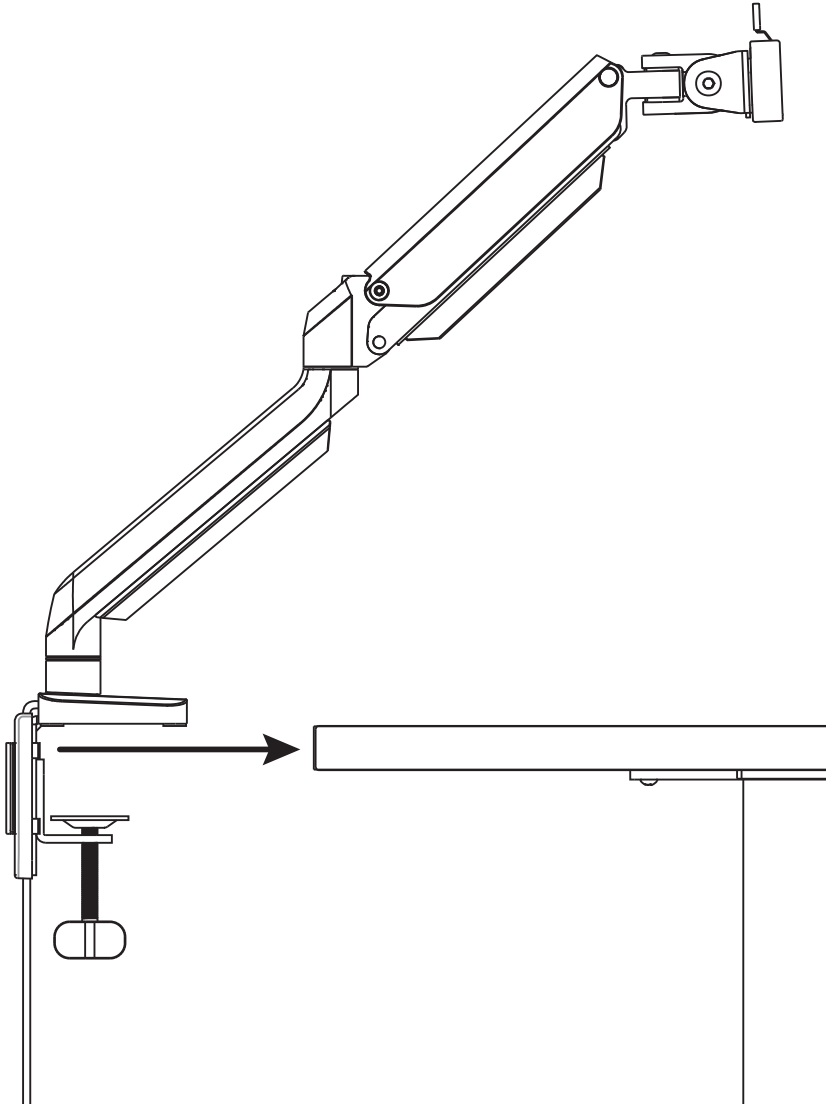

## MONITOR ARM ASSEMBLY INSTRUCTIONS

**Edge Mount Step 6:** Tighten the edge mount's knob until the monitor arm is secure.

Continue to Monitor Installation on page 23.

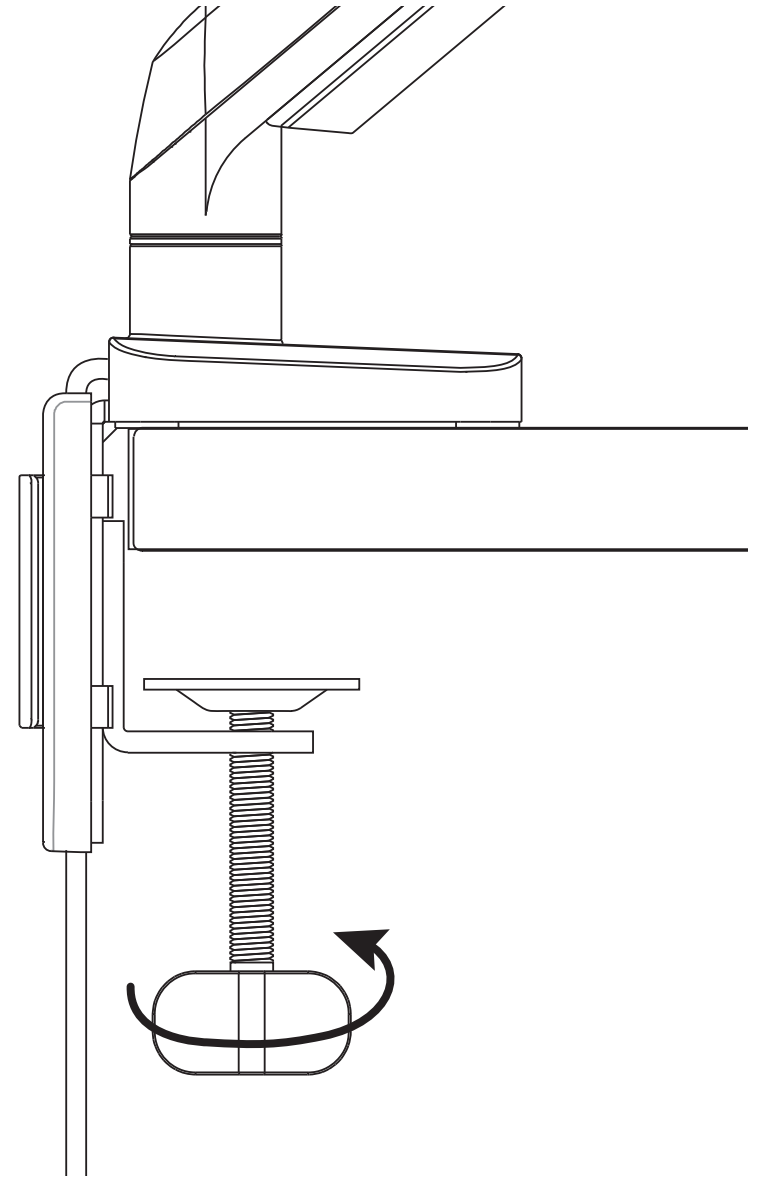

# MONITOR ARM ASSEMBLY INSTRUCTIONS

**Grommet/Bolt-through Step 1:** Insert the carriage bolt through the upper mounting plate.

See page 6 for edge-mount instructions or page 17 to install against a wall.

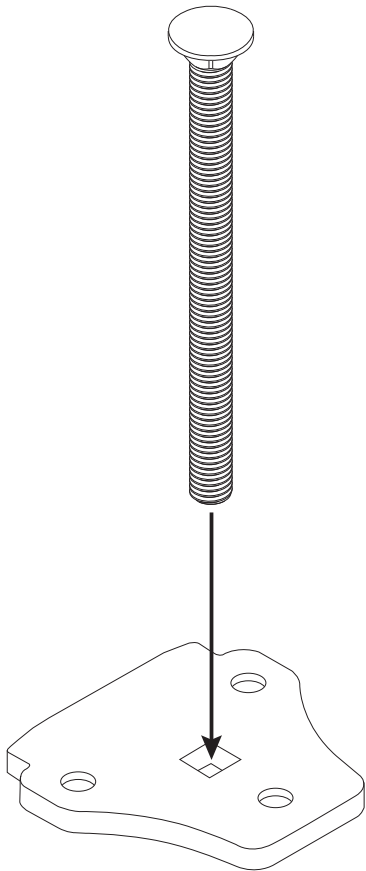

## 1:1 HARDWARE

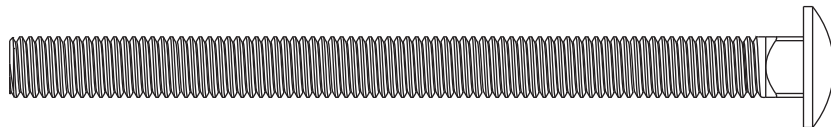

M8 x 105 mm Carriage Bolt



# MONITOR ARM ASSEMBLY INSTRUCTIONS

**Grommet/Bolt-through Step 2:** Attach the upper mounting plate to the monitor arm's base.

Make sure the USB cables are correctly routed through the notches in the base before securing the upper mounting plate into place.

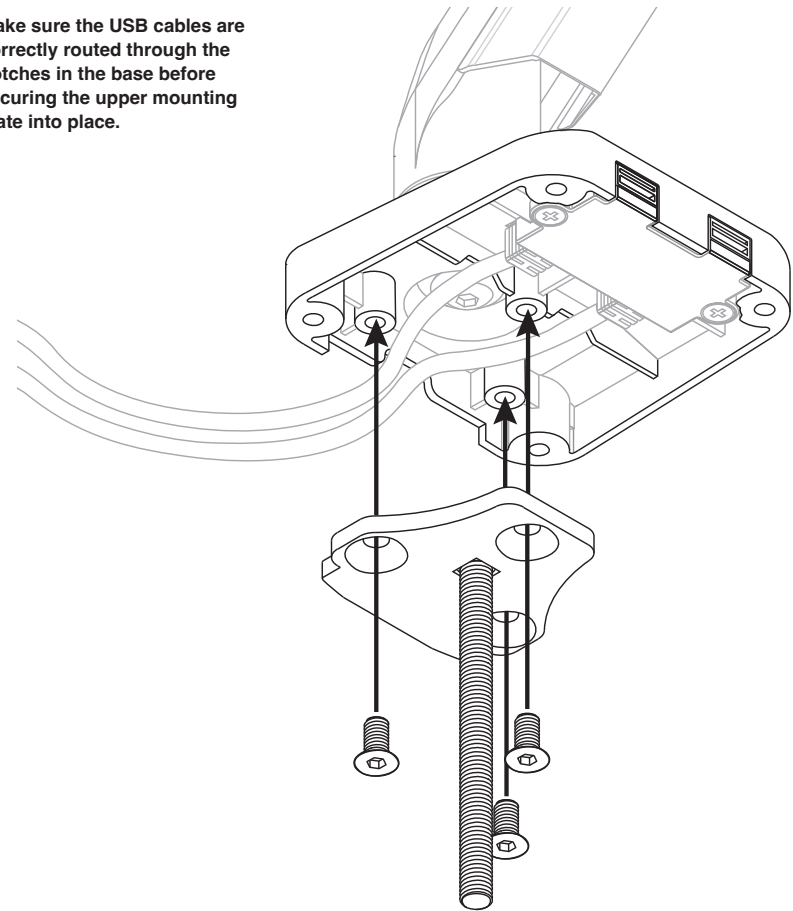

## 1:1 HARDWARE



M6 x 12 mm Screw

## TOOLS



4 mm Hex Key

# MONITOR ARM ASSEMBLY INSTRUCTIONS

**Grommet/Bolt-through Step 3:** Peel the backing off the protective pads and adhere them to the monitor arm base.

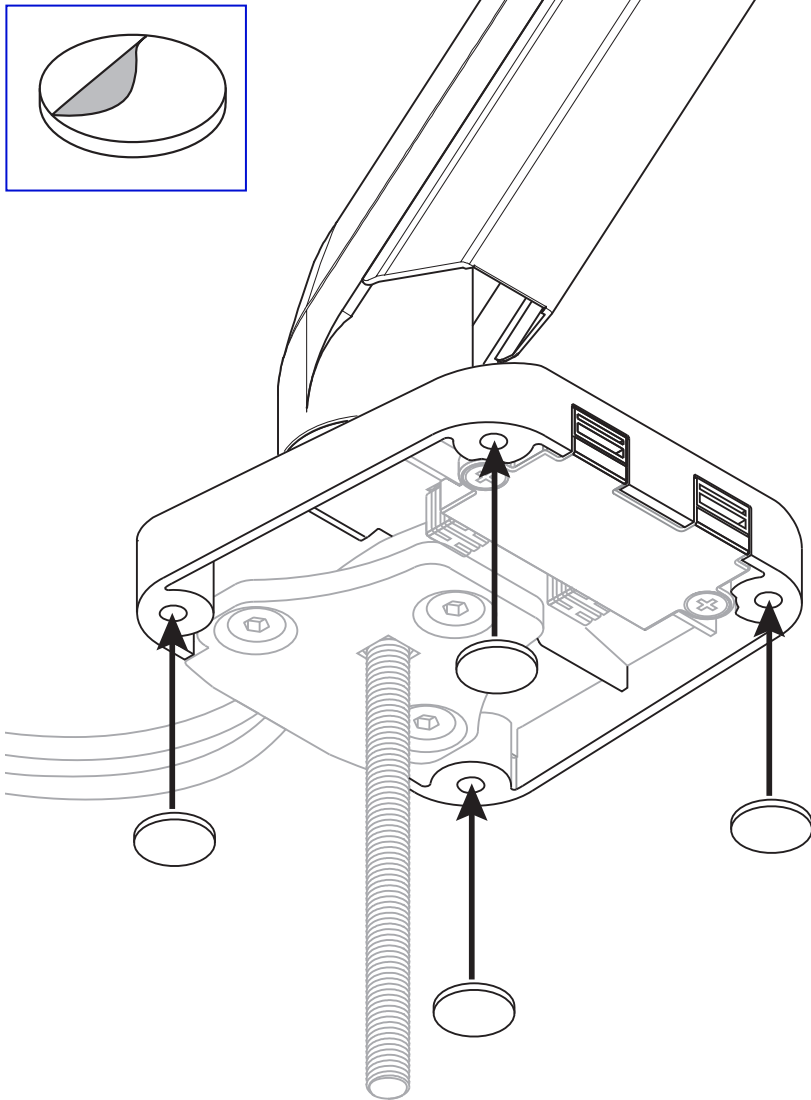

# MONITOR ARM ASSEMBLY INSTRUCTIONS

**Grommet/Bolt-through Step 4:** Insert the monitor arm through the tabletop's grommet hole.

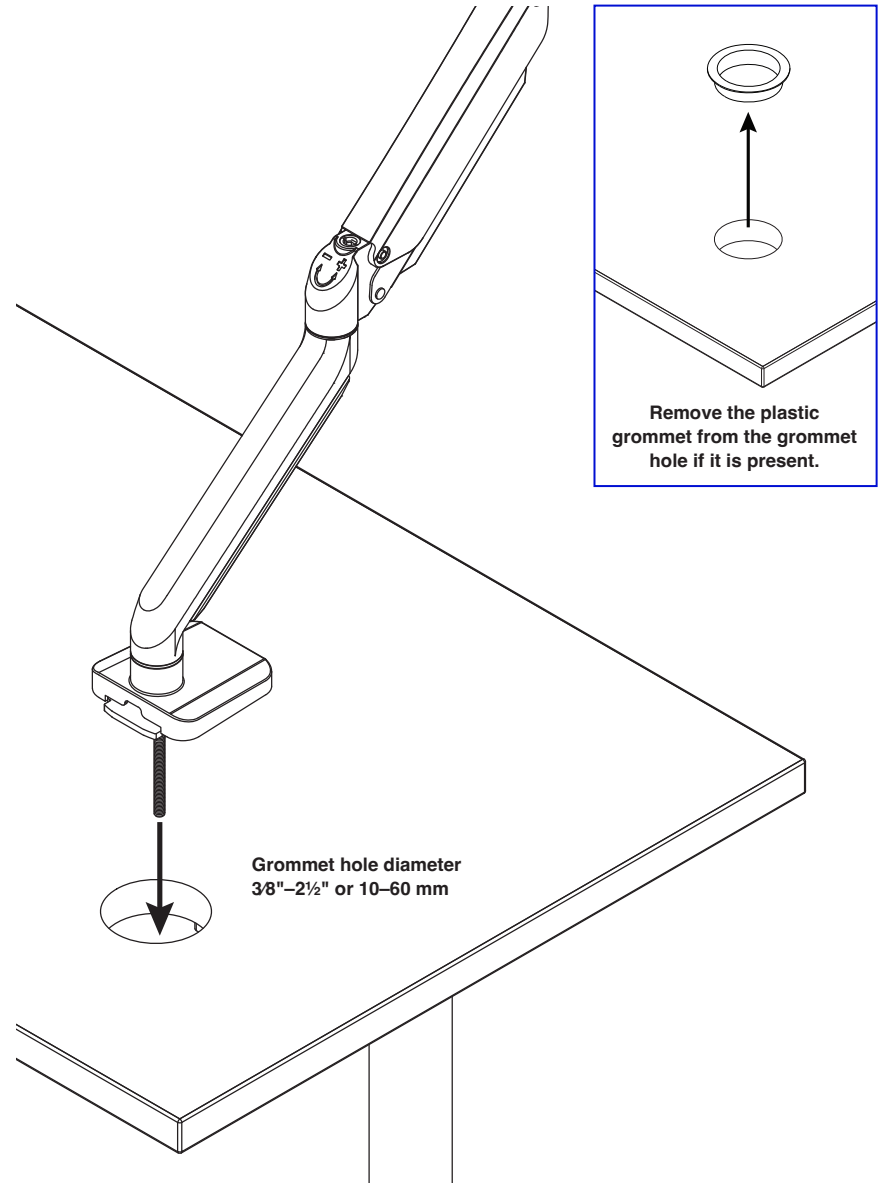



# MONITOR ARM ASSEMBLY INSTRUCTIONS

**Grommet/Bolt-through Step 5:** Slide the lower mounting plate, lock washer and hex nut onto the carriage bolt. Tighten the nut with the wrench.

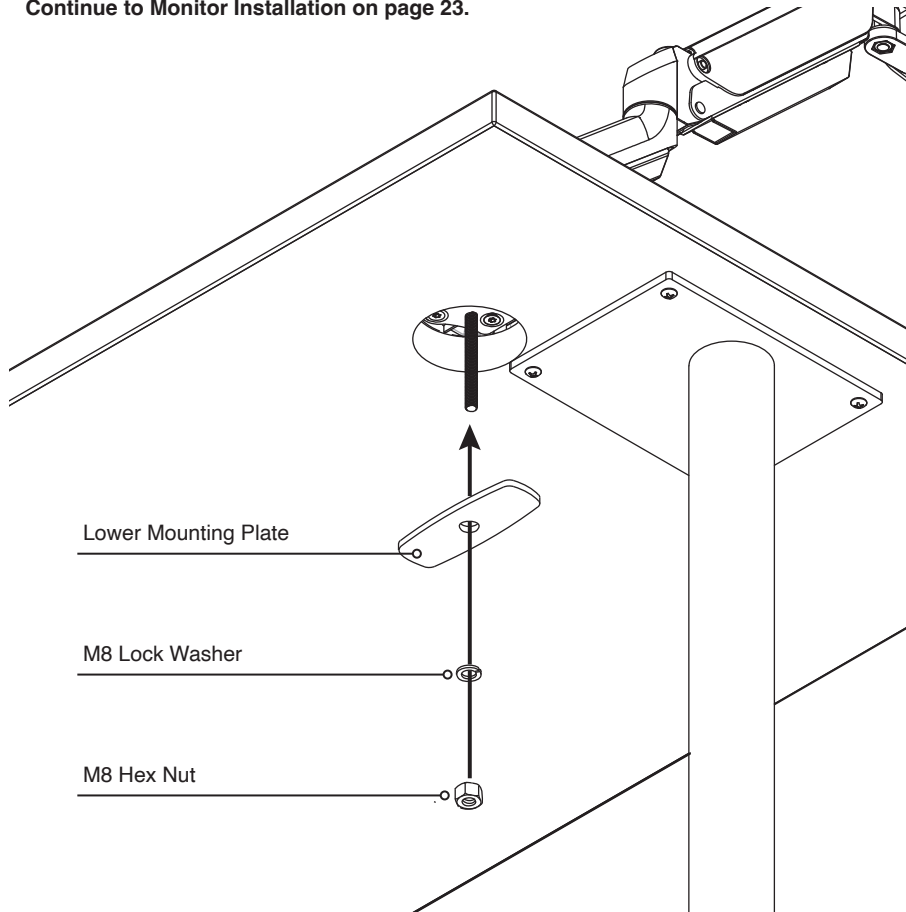
Continue to Monitor Installation on page 23.

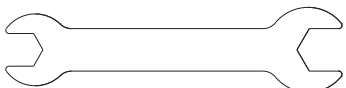

1:1 HARDWARE		TOOLS
		
M8 Lock Washer	M8 Hex Nut	Open End Wrench





# MONITOR ARM ASSEMBLY INSTRUCTIONS

**Against a Wall Step 1:** Attach the upper bracket to the monitor arm's base.

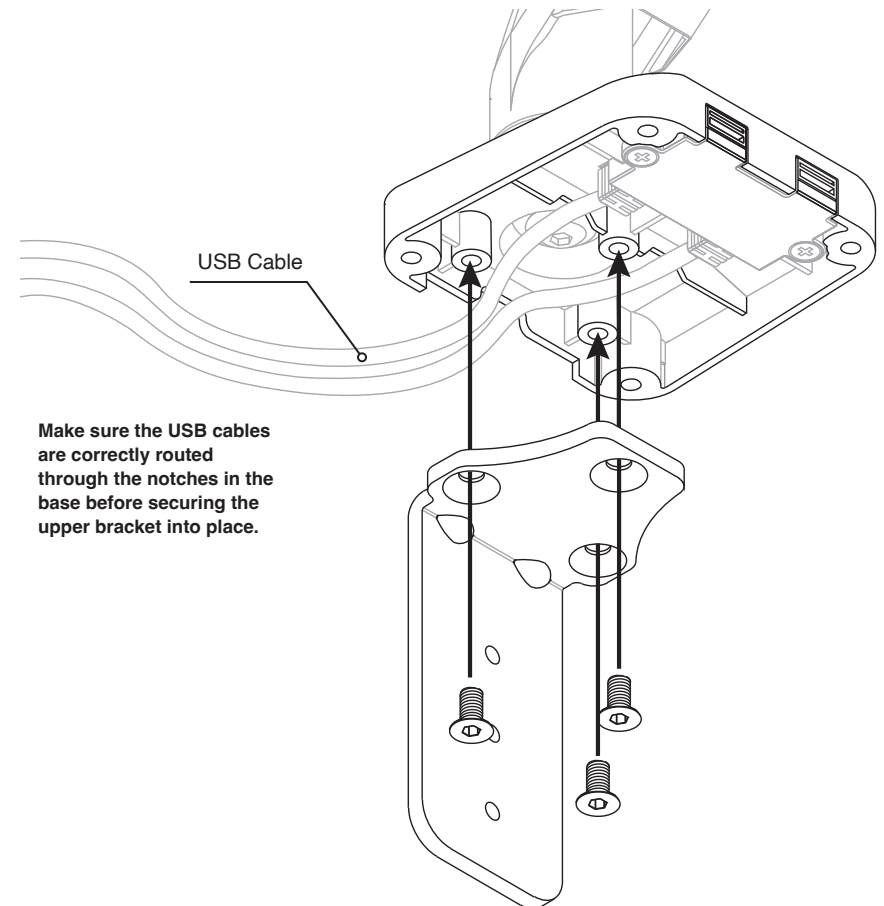
See page 6 for edge-mount instructions or page 17 to install against a wall.

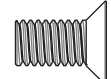

1:1 HARDWARE	TOOLS
	
M6 x 12 mm Screw	4 mm Hex Key

# MONITOR ARM ASSEMBLY INSTRUCTIONS

**Against a Wall Step 2:** Peel the backing off the protective pads and adhere them to the monitor arm base.

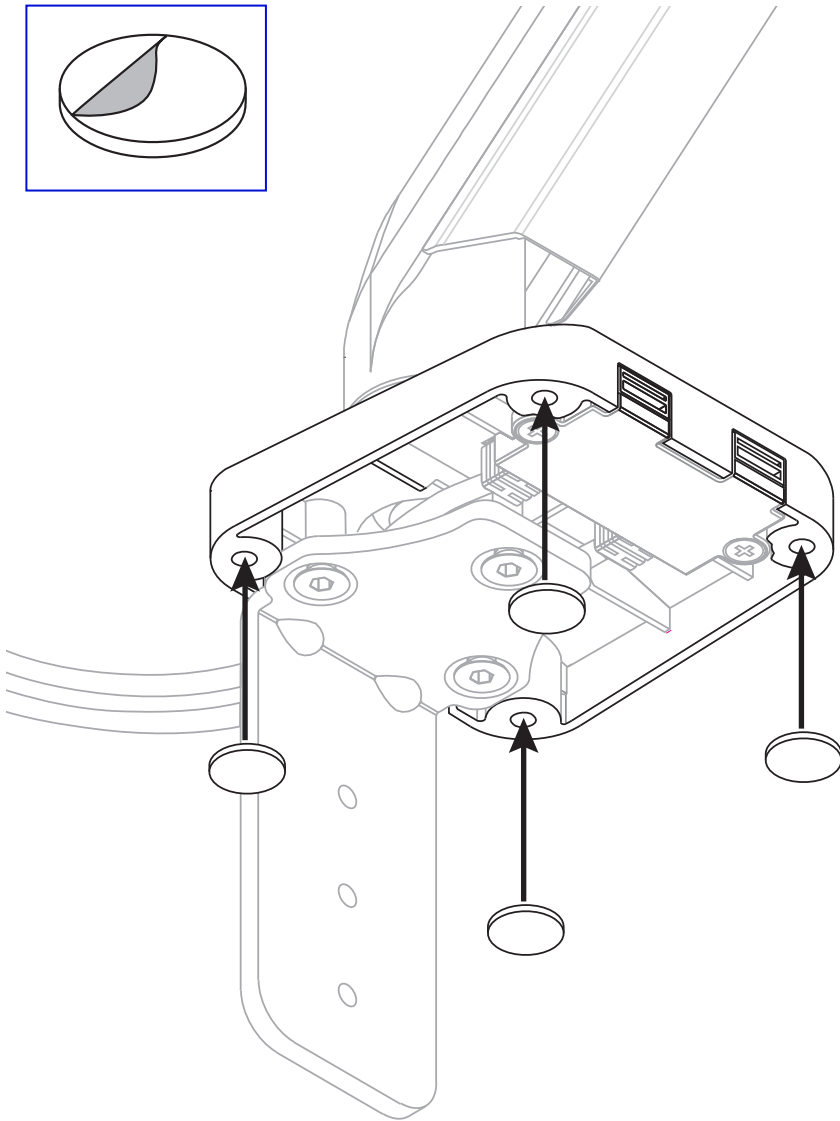
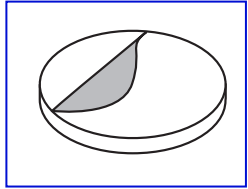

# MONITOR ARM ASSEMBLY INSTRUCTIONS

**Edge Mount Step 3:** Snap the cable clamp cover to the cable clamp.

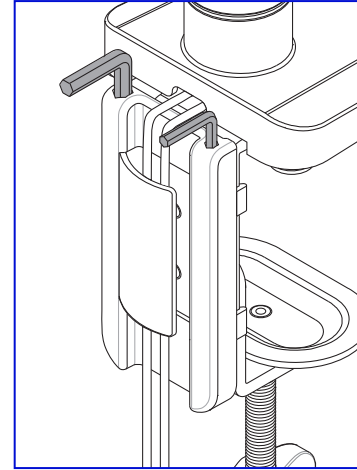

Cable cover clamp includes a place to store the provided hex keys.

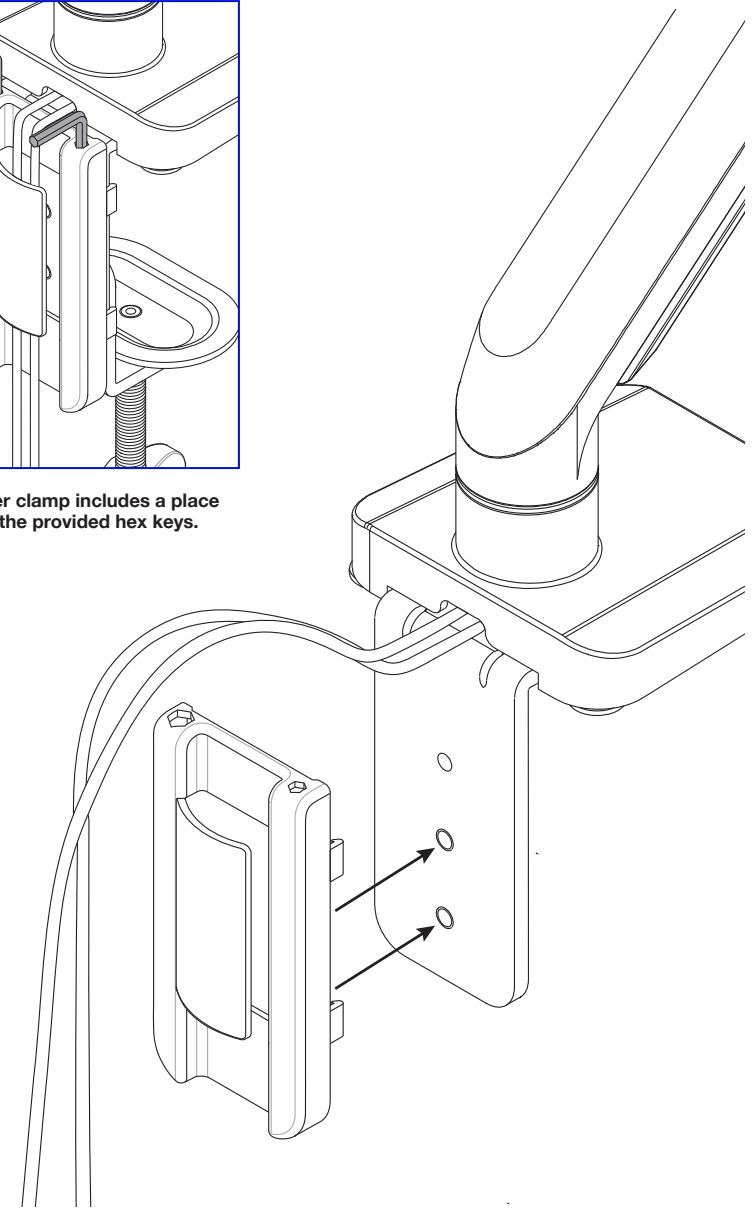

# MONITOR ARM ASSEMBLY INSTRUCTIONS

**Against a Wall Step 4:** Insert the monitor arm behind the tabletop.

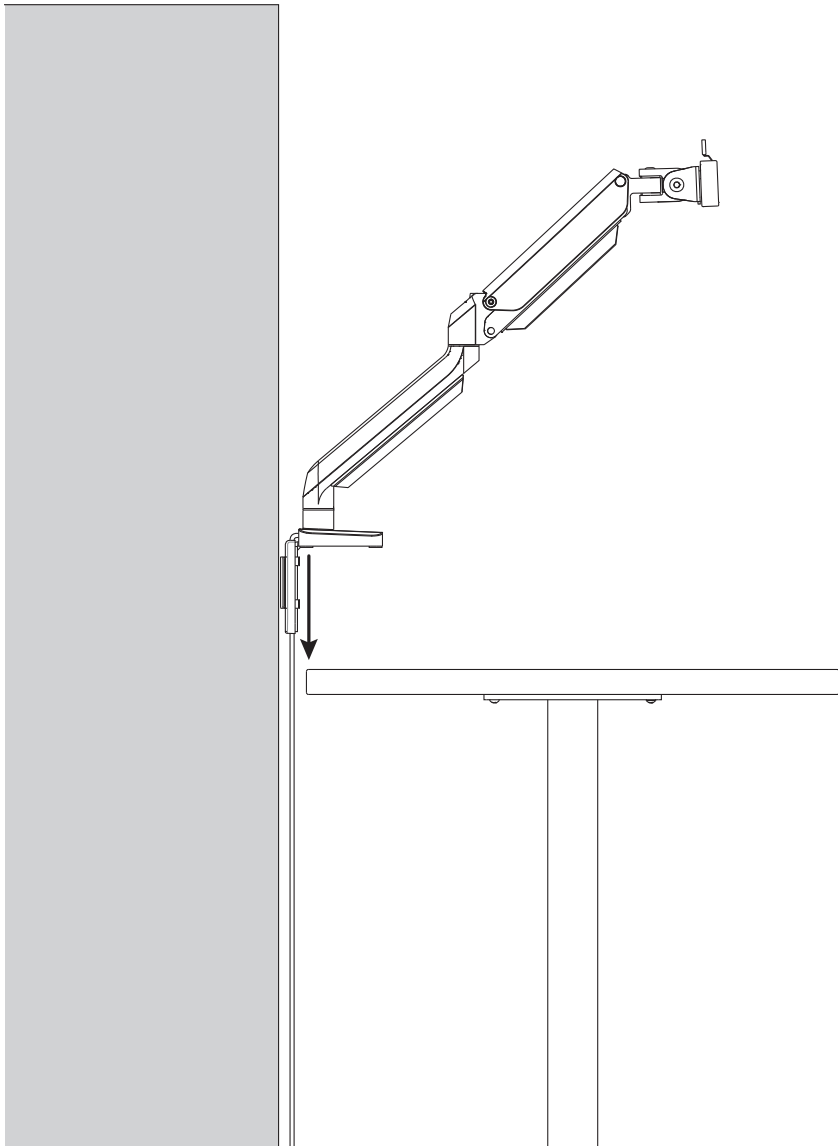

# MONITOR ARM ASSEMBLY INSTRUCTIONS

**Against a Wall Step 5:** Attach the bottom bracket.

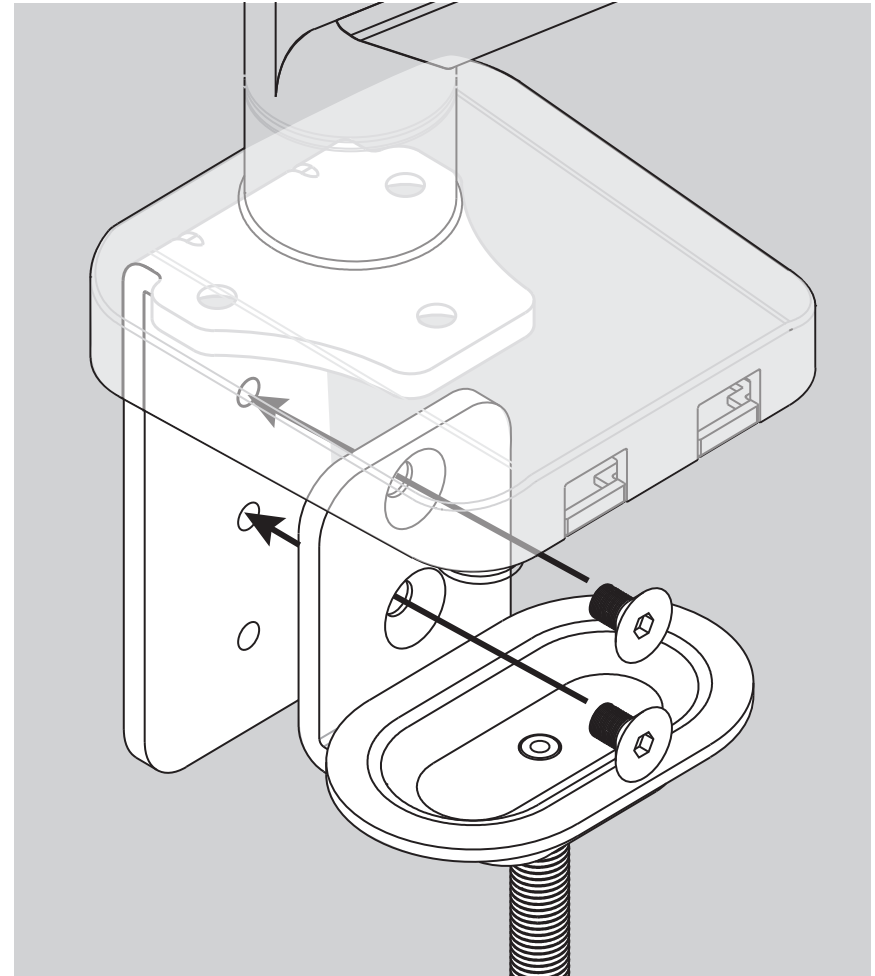

## 1:1 HARDWARE

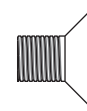

M6 x 10 mm Screw

## TOOLS



4 mm Hex Key

# MONITOR ARM ASSEMBLY INSTRUCTIONS

**Against a Wall Step 6:** Tighten the edge mount's knob until the monitor arm is secure.

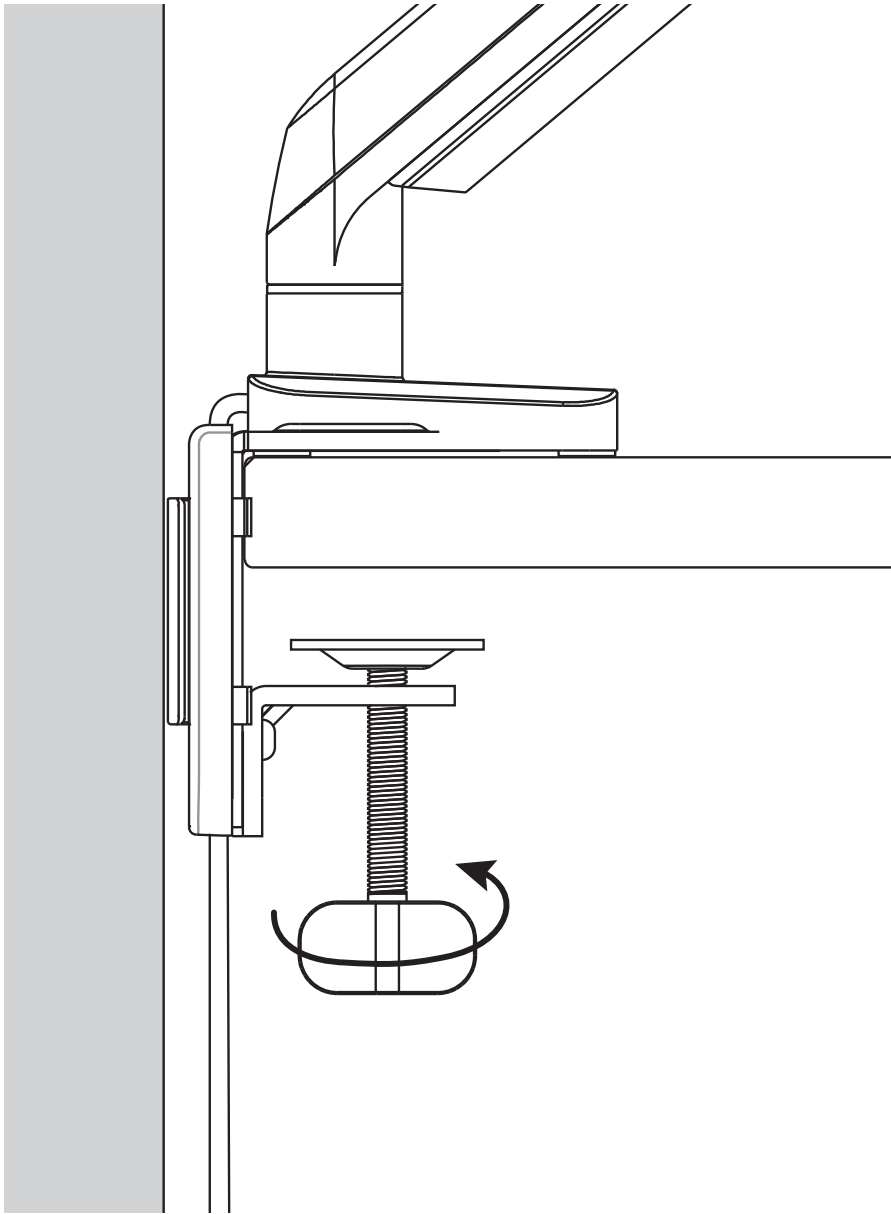

# MONITOR ARM ASSEMBLY INSTRUCTIONS

**Monitor Installation Step 1:** Attach the VESA plate to the monitor.

Be sure to use choose the screw with the size that correctly fits your monitor.

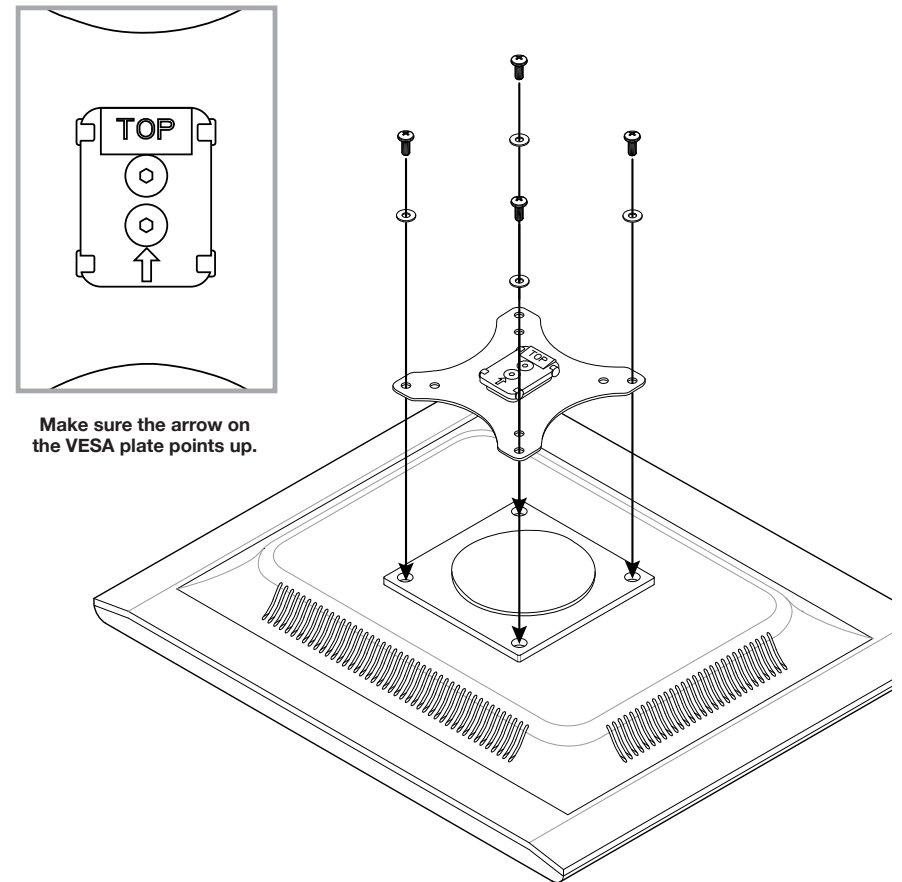

Make sure the arrow on the VESA plate points up.

## 1:1 HARDWARE



M4 x 12 mm  
Screw

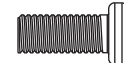

M5 x 12 mm  
Screw



M5 Flat  
Washer

## TOOLS

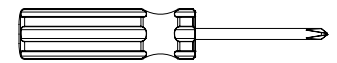

#2 Phillips  
Screwdriver



## MONITOR ARM ASSEMBLY INSTRUCTIONS

**Monitor Installation Step 2:** Pull back tab and snap the monitor's VESA plate onto the monitor arm.

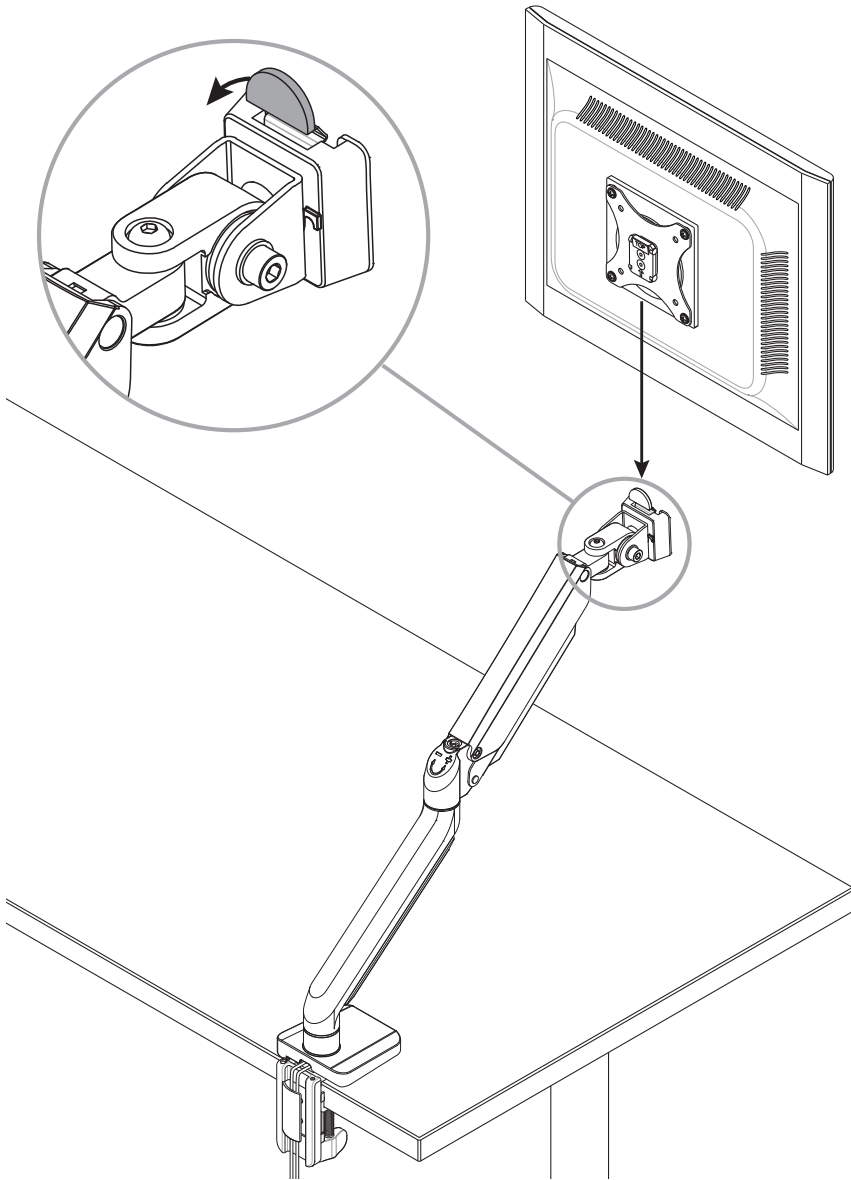

## MONITOR ARM ASSEMBLY INSTRUCTIONS

**Monitor Installation Step 3:** Slide the cable covers up and off the arm.

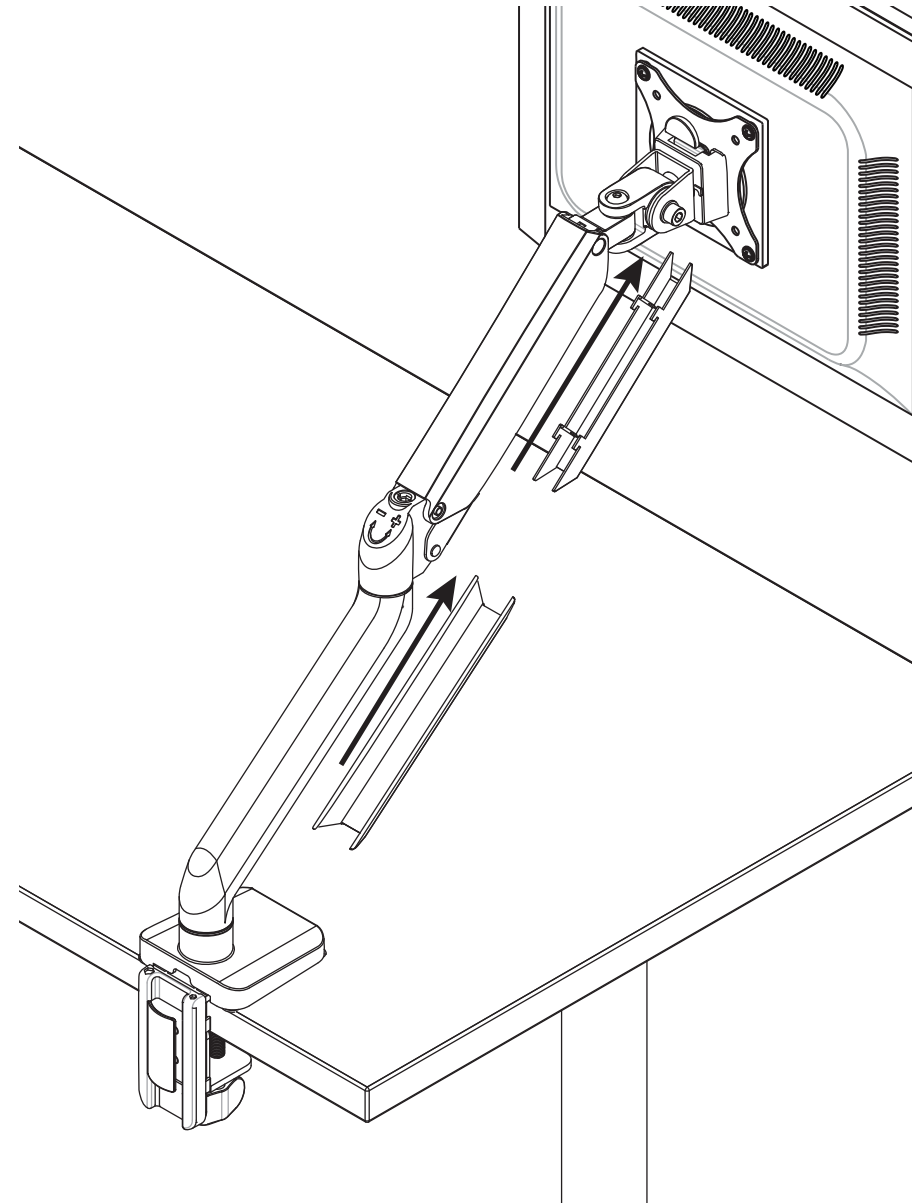

# MONITOR ARM ASSEMBLY INSTRUCTIONS

**Monitor Installation Step 4:** Route the cables along the cable covers and through the cable clamp cover. Slide the covers back down along the arm to reattach them.

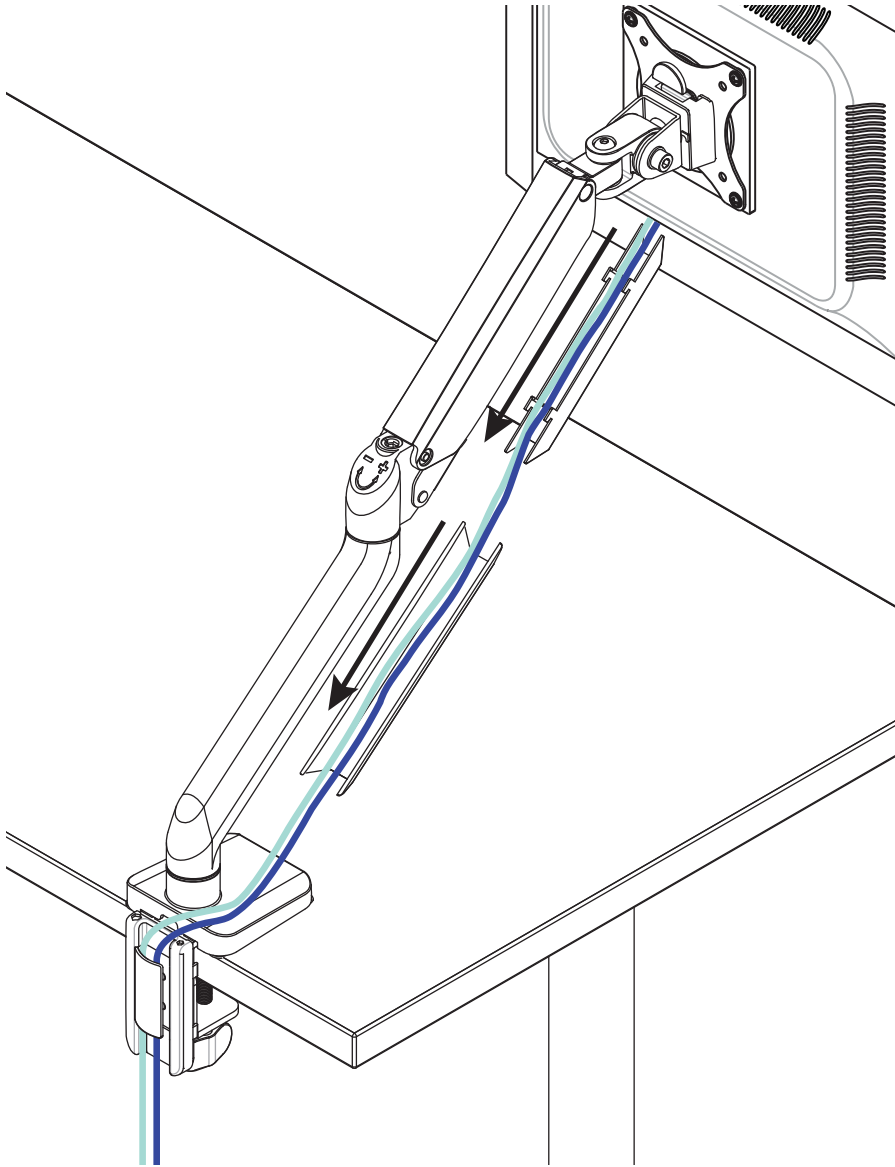

# MONITOR ARM ASSEMBLY INSTRUCTIONS

## Weight Capacity Adjustment

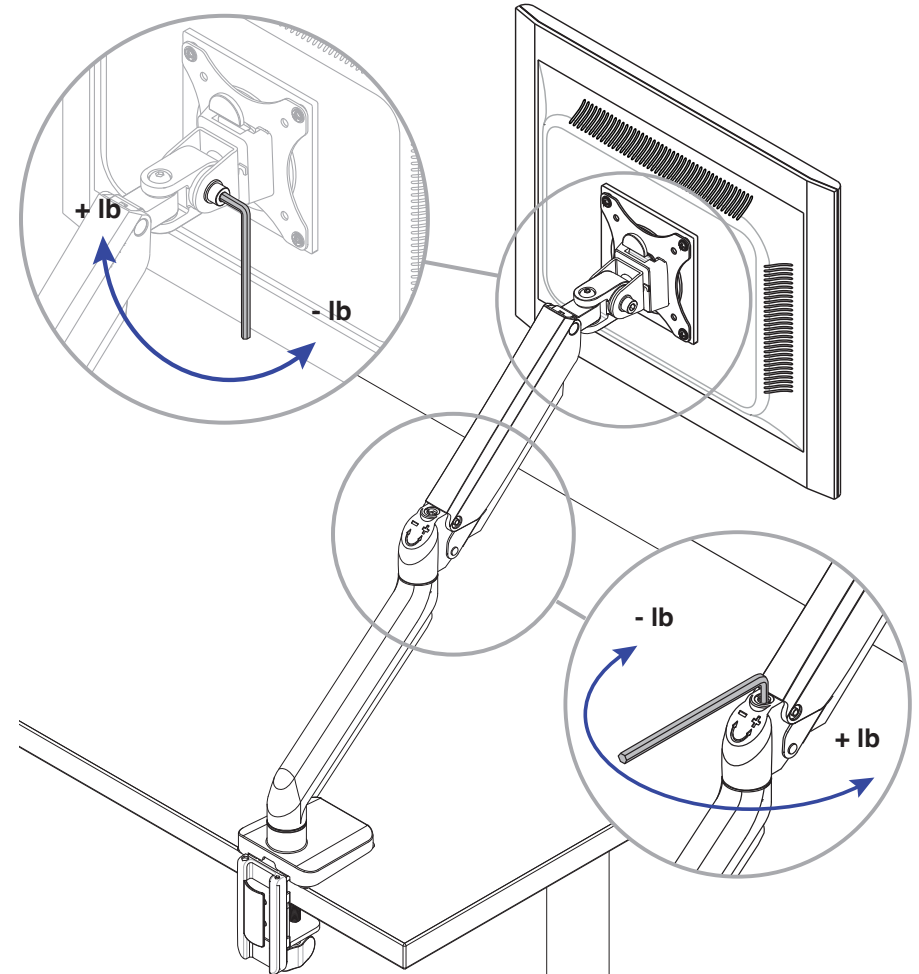

### TOOLS



6 mm Hex Key



# Surge

## ASSEMBLY INSTRUCTIONS

### *Well-made wellness.*

Add elevated design and sound ergonomics to any workspace with our Surge height-adjustable table. Its rugged dual-beam base is one of the quickest to assemble in the industry and can take on extra weight, giving you more tabletop options — all while providing peace of mind with enhanced safety features, including meeting BIFMA X5.5 standards.

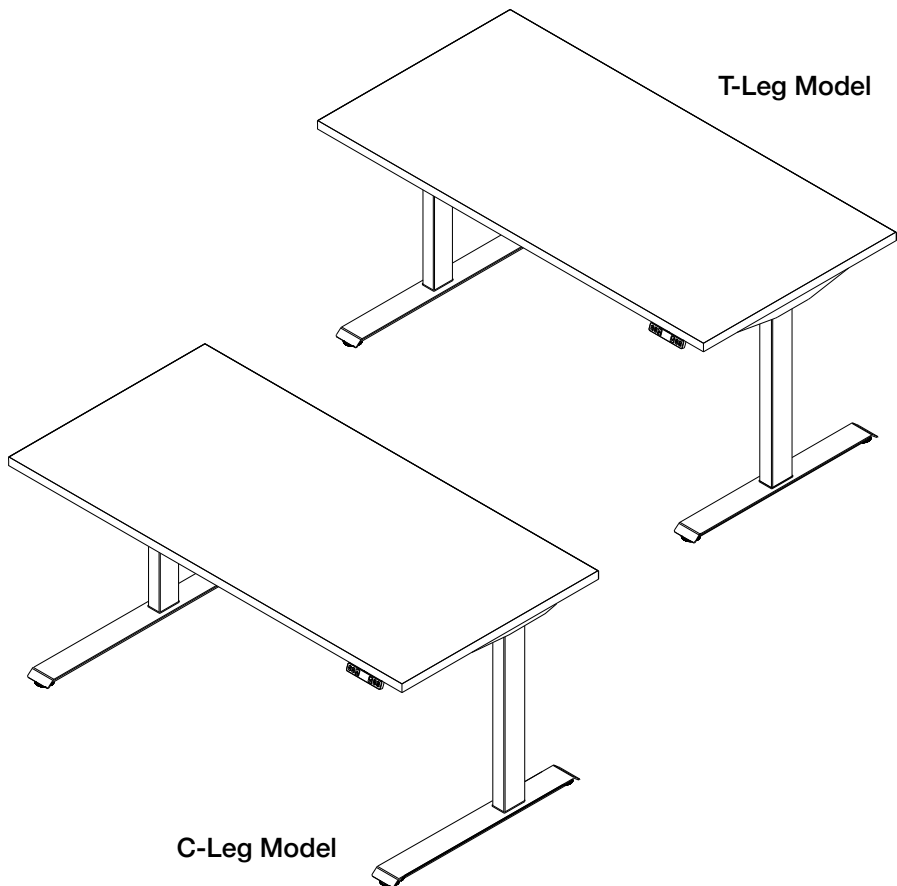

Read the entire instruction manual before you start installation and assembly. If you have any questions regarding any of the instructions or warnings, please contact your local distributor for assistance.

To report any issues with this product, contact our customer experience team at: (888) 274-8664 or [sitonit@exemplis.com](mailto:sitonit@exemplis.com).

## IMPORTANT SAFETY INSTRUCTIONS

---

**Read all instructions before using this product. Save these instructions.**

When using an electrical product, basic precautions should always be followed, including the following.

### **DANGER: TO REDUCE THE RISK OF ELECTRIC SHOCK**

### **Use Care When Cleaning**

Always unplug this furnishing from the electrical outlet before cleaning. Follow all cleaning guidelines provided by the manufacturer.

## IMPORTANT SAFETY INSTRUCTIONS

---

**WARNING: TO REDUCE THE RISK OF BURNS, FIRE, ELECTRIC SHOCK, OR INJURY TO PERSONS**

### **Keep Dry and Use Care When Cleaning**

Keep all electrical components away from water and humidity. Do not operate where aerosol (spray) products are being used or where oxygen is being administered.

Do not use outdoors. This equipment is approved for indoor use only.

### **Do Not Modify**

Use this product only for its intended use as described in these instructions. Do not use attachments not recommended by the manufacturer.

### **Avoid Damage**

Keep the cord away from heated surfaces. Unplug from outlet before putting on or taking off parts. To disconnect, turn all controls to the off position, then remove plug from outlet.

### **Inspect Regularly**

Never operate this product if it has a damaged cord or plug, if it is not working properly, if it has been dropped or damaged, or dropped into water. Return the product to a service center for examination and repair.

Inspect table system regularly and immediately stop using the product if it is damaged or has loose parts.

## IMPORTANT SAFETY INSTRUCTIONS



### **WARNING / AVERTISSEMENT**

#### **RISK OF INJURY / RISQUE DE BLESSURE**

Max Load 265 lb, including worksurface

*Charge nominale 120 kg, incluant la surface de travail*



### **WARNING / AVERTISSEMENT**

#### **RISK OF FIRE AND SHOCK / RISQUE D'INCENDIE ET DE CHOC**

Use only min Power cord to be SJT type or equivalent, 18/3 AWG minimum, 300 V, 105 degree C

*Utilisez uniquement un type SJT minimum ou équivalent, cordon 18 AWG minimum 300 V, 105 degré C*



### **WARNING / AVERTISSEMENT**

#### **RISK OF ELECTRIC SHOCK, FIRE, AND INJURY / RISQUE DE CHOC ÉLECTRIQUE, D'INCENDIE ET DE BLESSURE**

Review the assembly instructions to confirm that the appropriate critical components and accessories are being used with the furnishing

*Consultez les instructions d'assemblage pour confirmer que les composants et accessoires essentiels appropriés sont utilisés avec l'équipement*

## IMPORTANT SAFETY INSTRUCTIONS

---

### **Servicing of Double-Insulated Products**

In a double-insulated product, two systems of insulation are provided instead of grounding. No grounding means is provided on a double-insulated product, nor is a means for grounding to be added to the product. Servicing a double-insulated product requires extreme care and knowledge of the system and is to be done only by qualified service personnel. Replacement parts for a double-insulated product must be identical to the parts they replace. A double-insulated product is marked with the words "DOUBLE INSULATION" or "DOUBLE INSULATED".



## WARNING

### RISK OF DEATH AND SERIOUS INJURY

#### Do Not Overload Table

Make sure the table system is not overloaded by the weight of the tabletop and objects on table. Evenly distribute load; excess loads near the edges can reduce stability and lead to tip-over. Do not exceed maximum load of 265 lb.

#### Assemble With Care

Failure to follow instructions could result in product failure or potential injury. Keep fingers clear of pinch points

#### Use Care to Keep the Table From Tipping Over

Before moving the table system, clear all objects and equipment from the table to reduce the risk of tipping over. Do not lift the table system by the tabletop. Adjust the table to its lowest height before moving. In order to avoid risk of tipping or collapse, make sure corded objects will not be pulled off the table or cause other objects to fall.

#### Clearance Around the Table

Confirm that the surroundings on all sides of the table system are clear and make sure the power cord moves freely as desk moves up and down.

If the tabletop encounters resistance while moving, it will rebound.

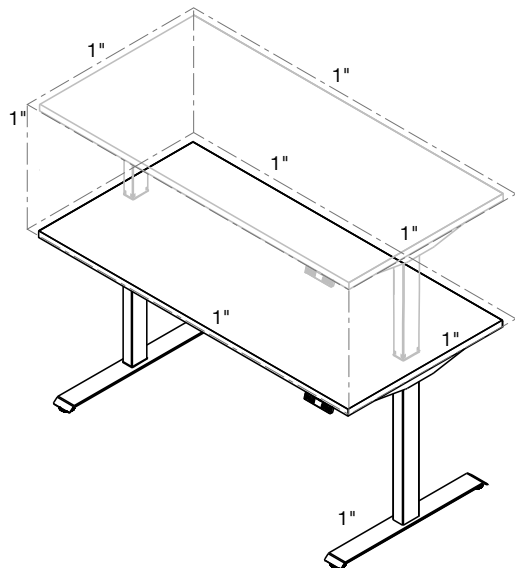

## Recommended Tools

---

- Cordless Drill/Driver
- #1 Phillips Bit
- #2 Phillips Bit
- 5 mm Hex Key

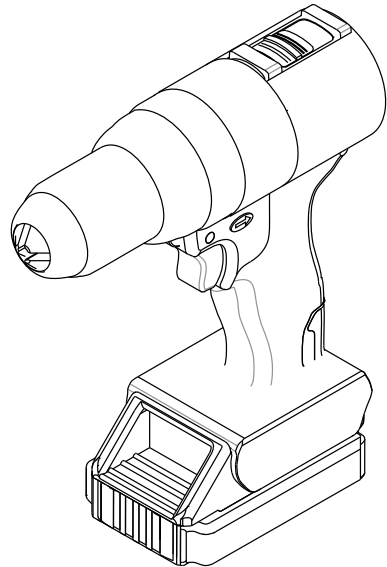
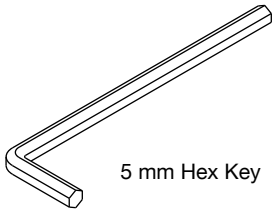

## Parts

- Top Supports (2)
- Columns (2)
- Feet (2)
- Frame (1)
- Hardware
  - M6 × 35 mm Screws (8)

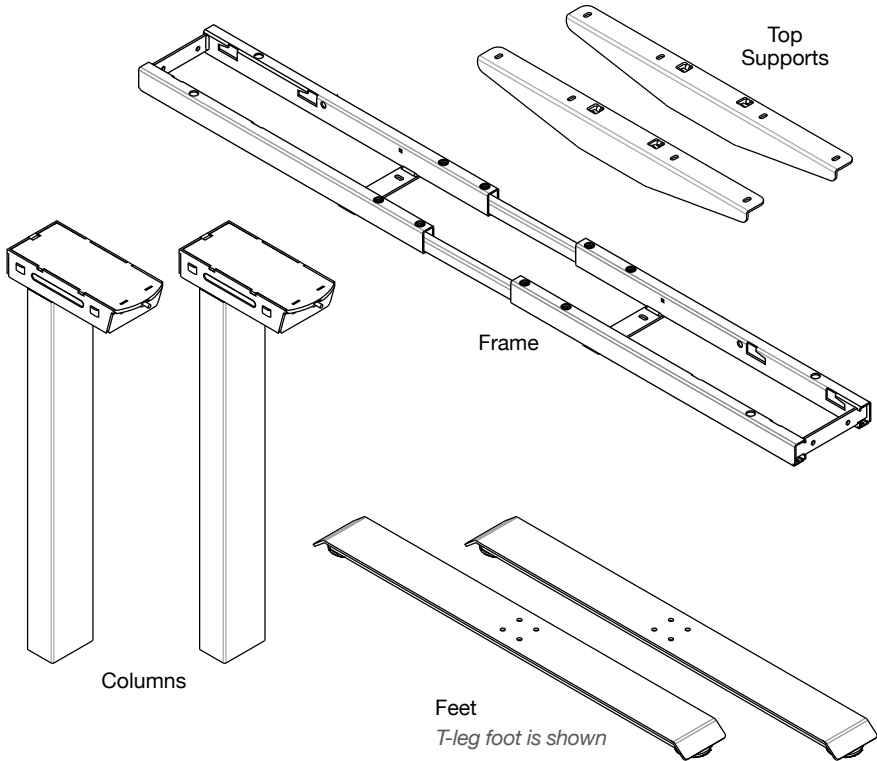

### HARDWARE

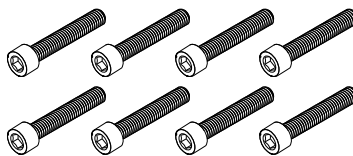

M6 × 35 mm Screws

## Parts

- Hand Control (1)
- Control Box (1)
- Cam Lock (2)
- Hairpin Clip (2)
- Extension Cable (2v)
- A/C Cable (1)
- **Cable Management**
  - Cable Clip (4)
  - Small P-Clip (10)
- **Hardware**
  - M3 × 20 mm Screw (3)
  - M5 × 20 mm Screw (12)
  - M5 × 25 mm (2)
  - M3.5 × 16 mm Screw (10)

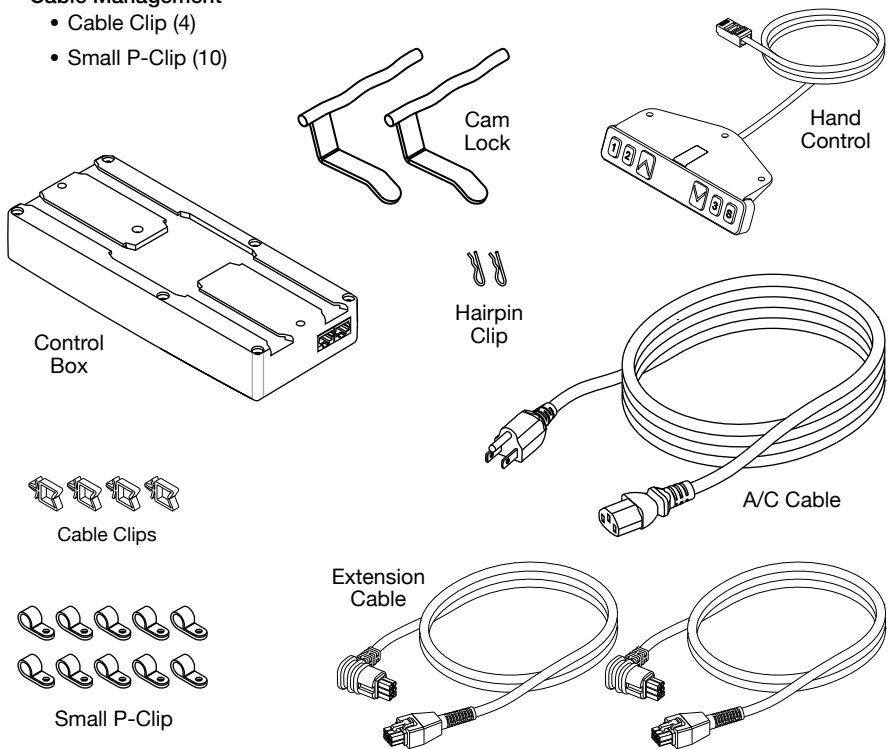

### HARDWARE

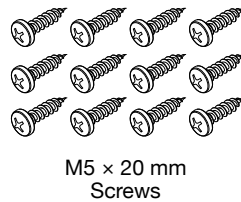
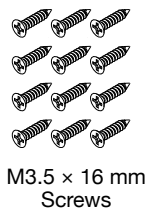

# Surge ASSEMBLY INSTRUCTIONS

**Step 1:** Attach the frame to the top supports.

*T-leg model is shown.  
C-leg step 1 is the same.*

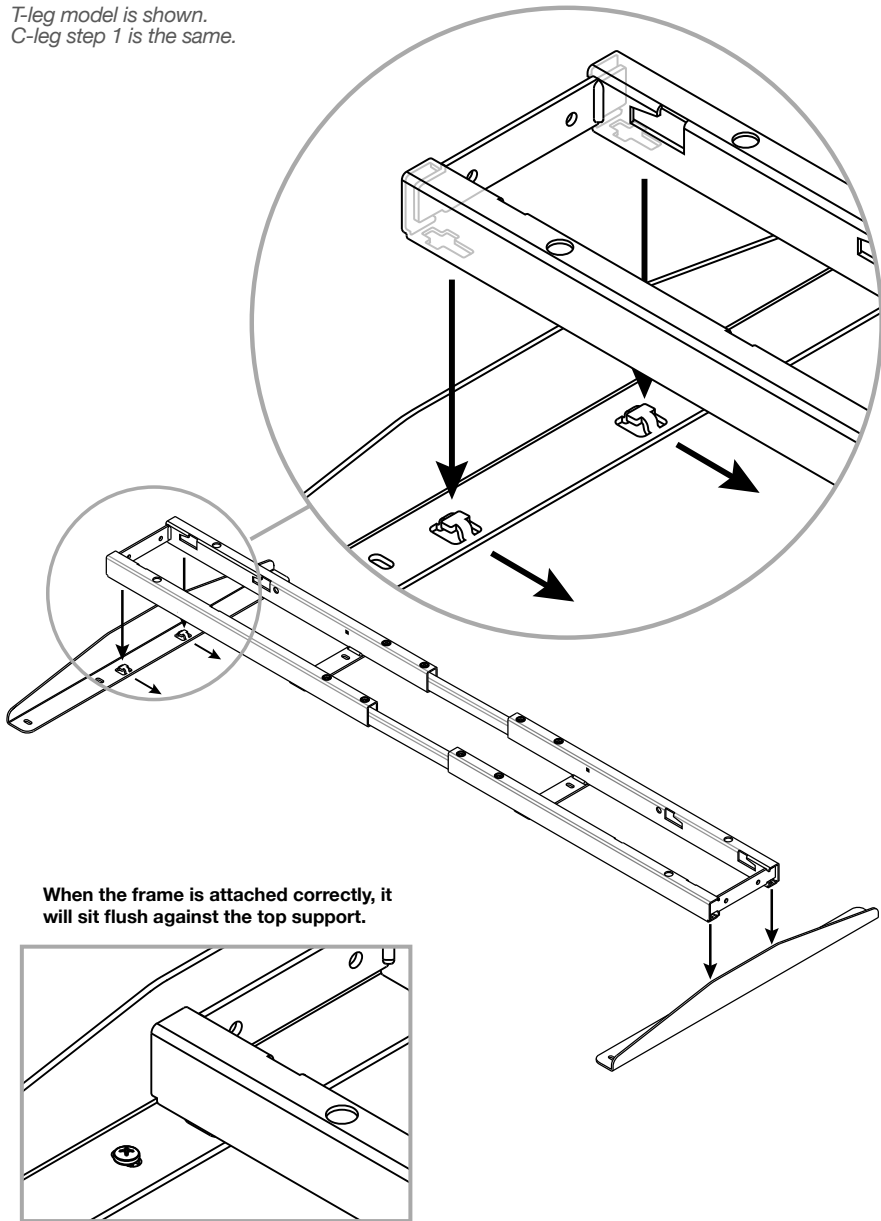

**Step 2 (T-Leg):** Loosen the set screws on the telescoping cross bars and pull the frame apart to align it with pilot holes.

Refer to page 24 if tabletop does not have pilot holes.

*T-leg model is shown.  
See the following page for C-leg step 2.*

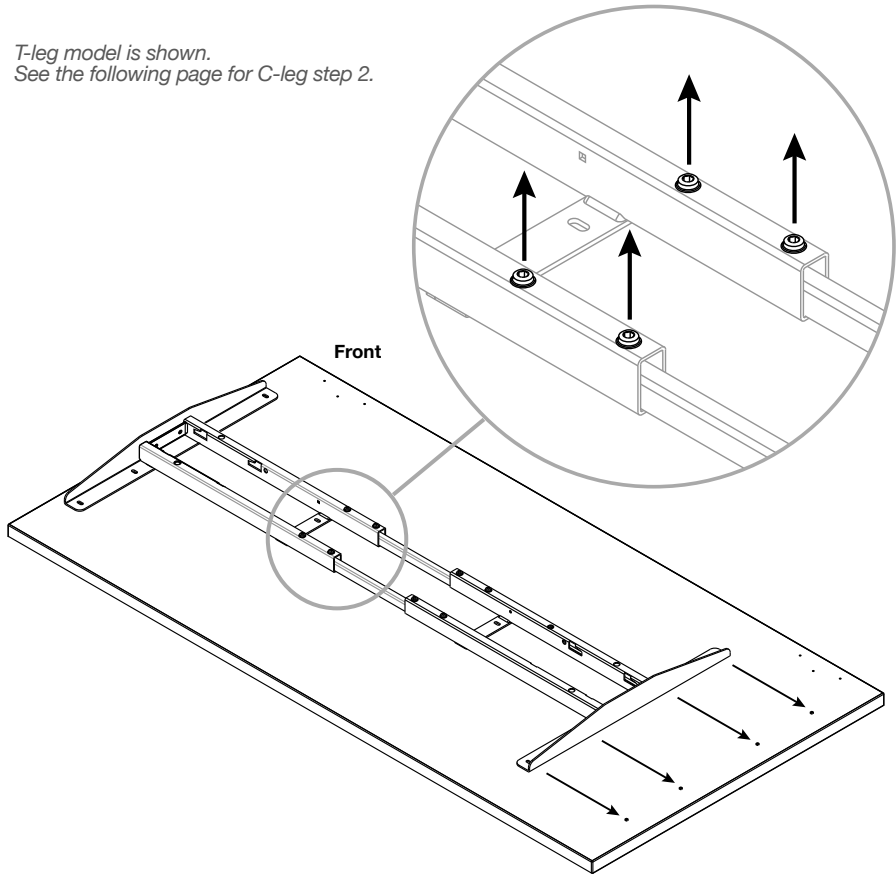

## TOOLS



5 mm Hex Key

**Step 2 (C-Leg):** Loosen the set screws on the telescoping cross bars and pull the frame apart to align it with pilot holes.

Refer to page 24 if tabletop does not have pilot holes.

*C-leg model is shown.  
See the previous page for T-leg step 2.*

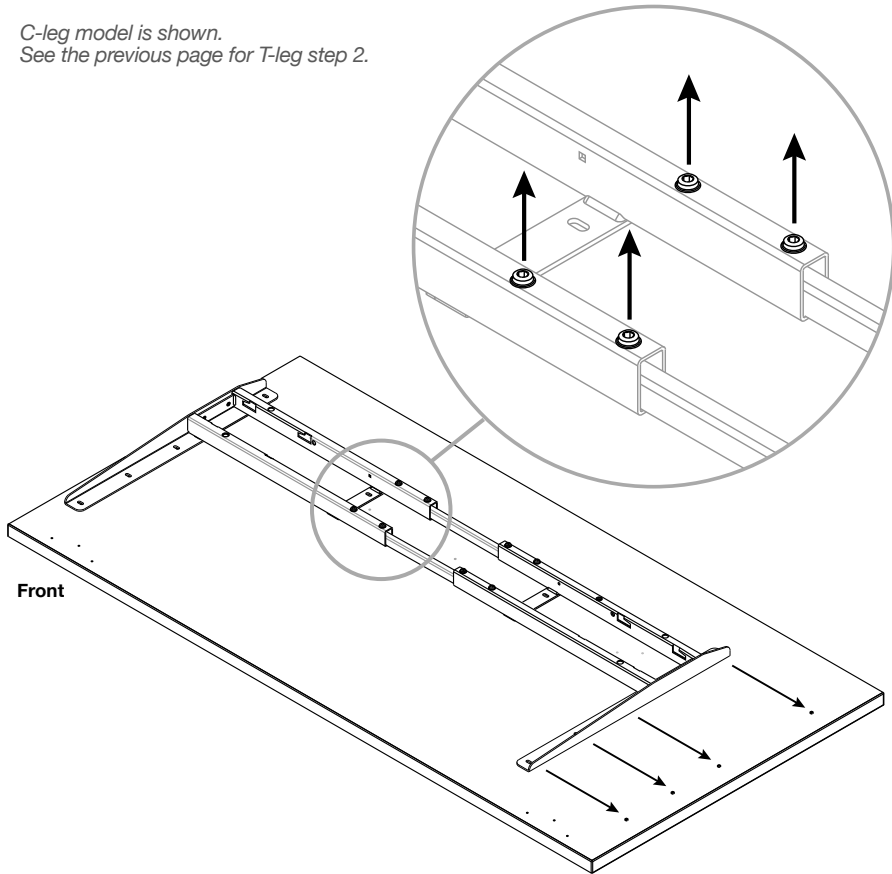

## TOOLS



5 mm Hex Key

**Step 3 (T-Leg):** Attach the frame to the tabletop.

Half the frame is shown below. Attach the screws on both sides.

*T-leg model is shown.  
See the following page for C-leg step 3.*

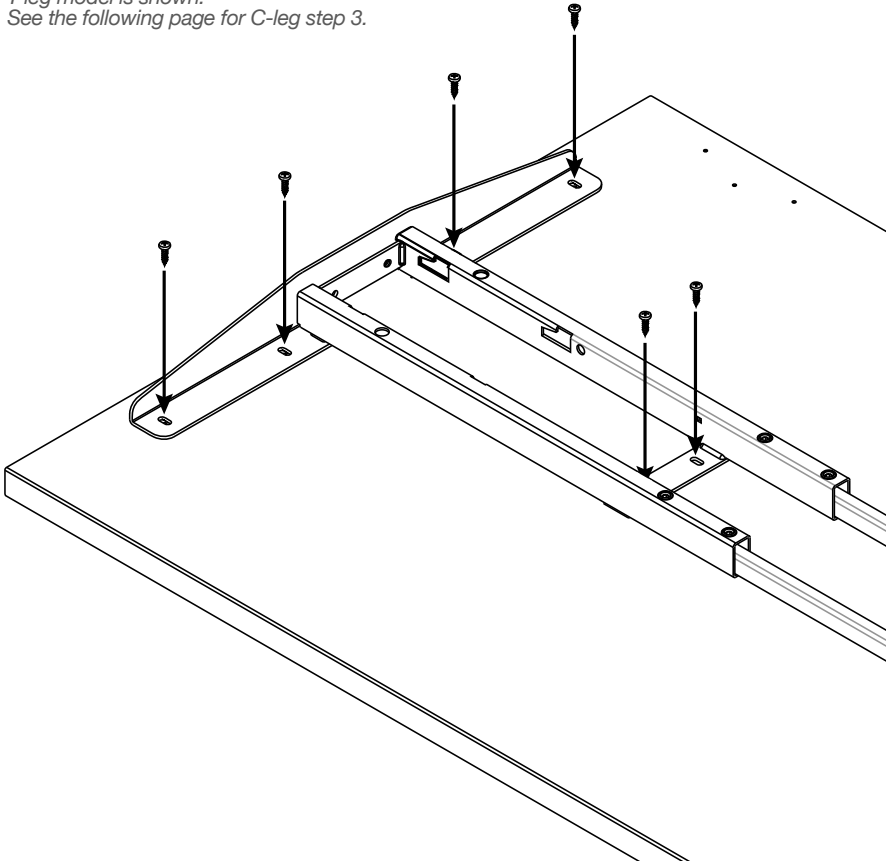

**1:1 HARDWARE**

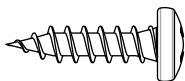

M5 x 20 mm Screw

**TOOLS**

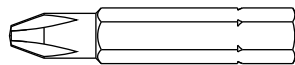

#2 Phillips Bit

**Step 3 (C-Leg):** Attach the frame to the tabletop.

Half the frame is shown below. Attach the screws on both sides.

*C-leg model is shown.  
See the previous page for T-leg step 3.*

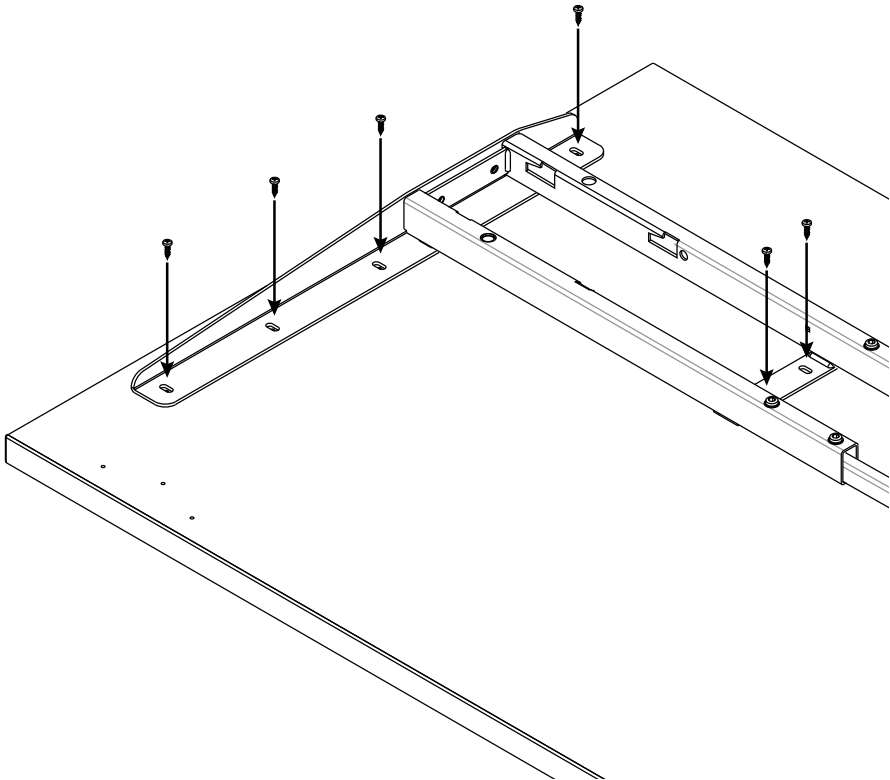

**1:1 HARDWARE**

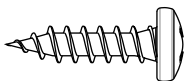

M5 x 20 mm Screw

**TOOLS**

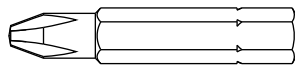

#2 Phillips Bit

# Surge

## ASSEMBLY INSTRUCTIONS

**Step 4:** Insert the tabs of the columns into the slots in the frame and push the columns towards the side beams to secure them.

*T-leg model is shown.  
C-leg step 4 is the same.*

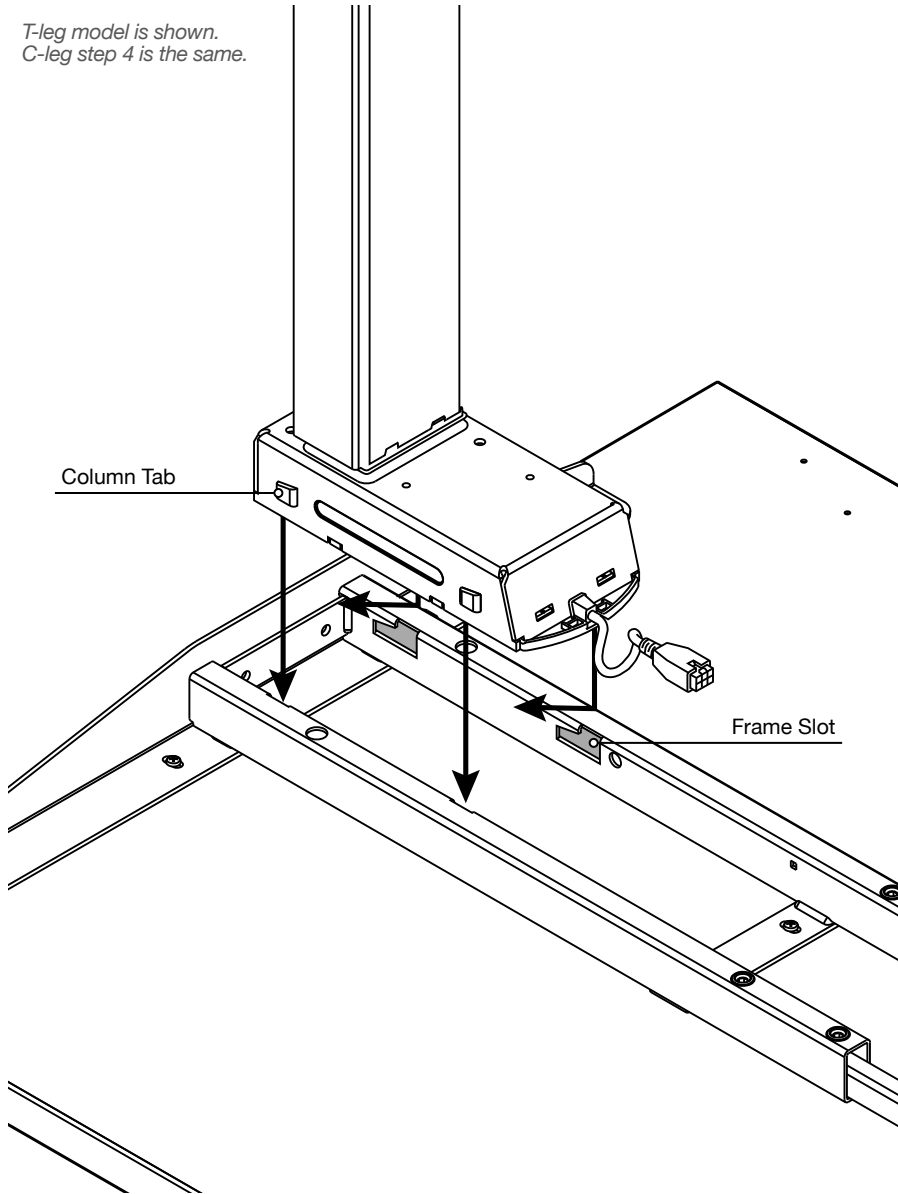

**Step 5:** Insert the cam lock into frame long-end first.

Cam lock steps need to be applied to both columns.

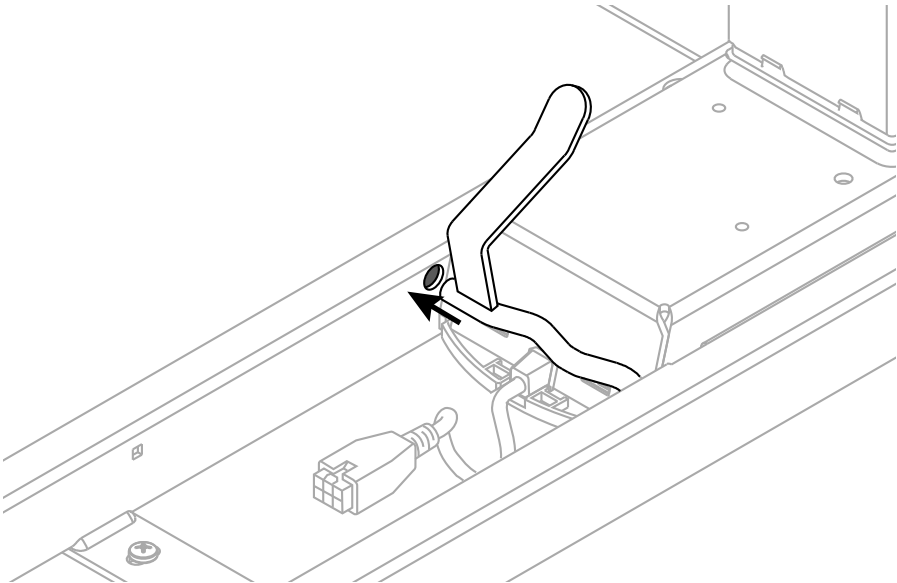
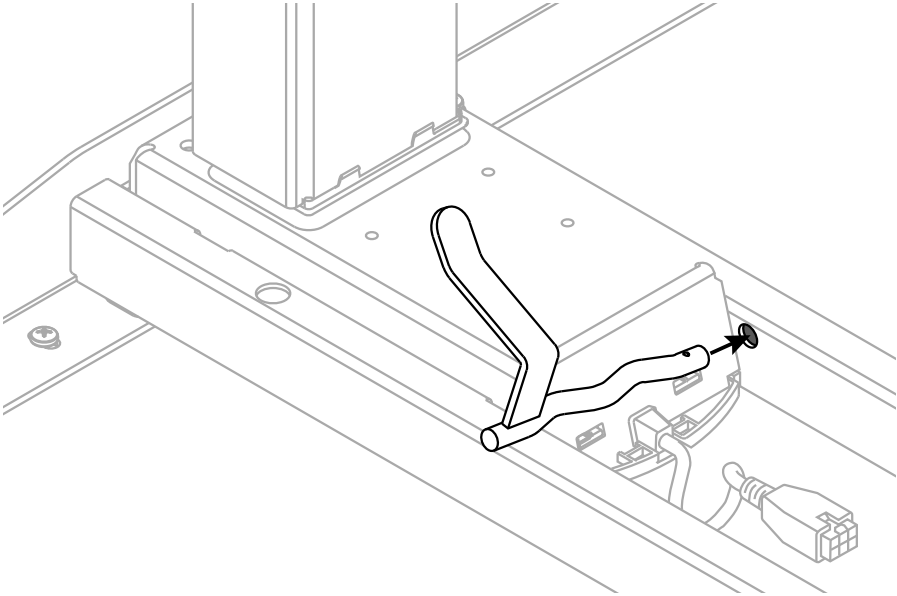

**Step 6:** Press the cam lock down and use the hair pin clip to secure it in place.

Cam lock steps need to be applied to both columns.

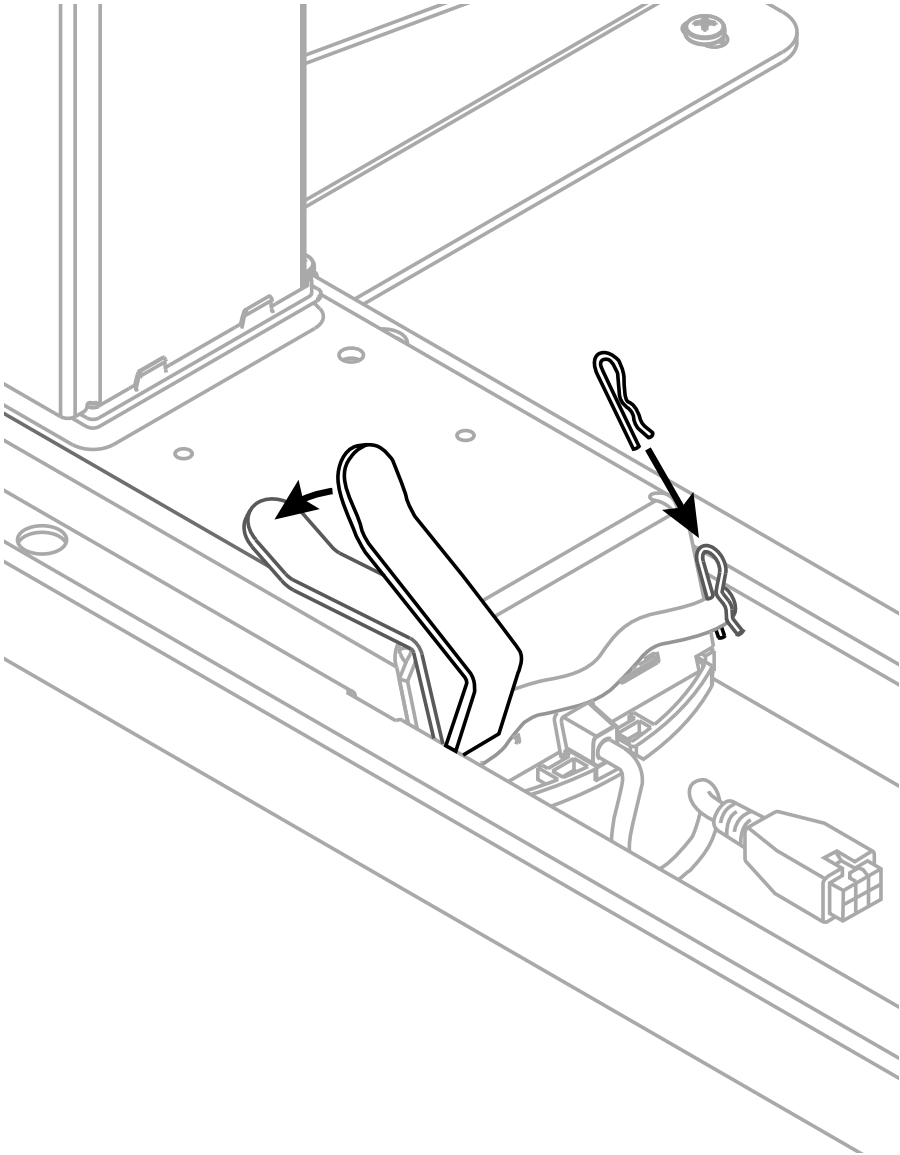

**Step 7:** Attach the feet to the columns.

*T-leg model is shown.  
C-leg step 7 is the same.*

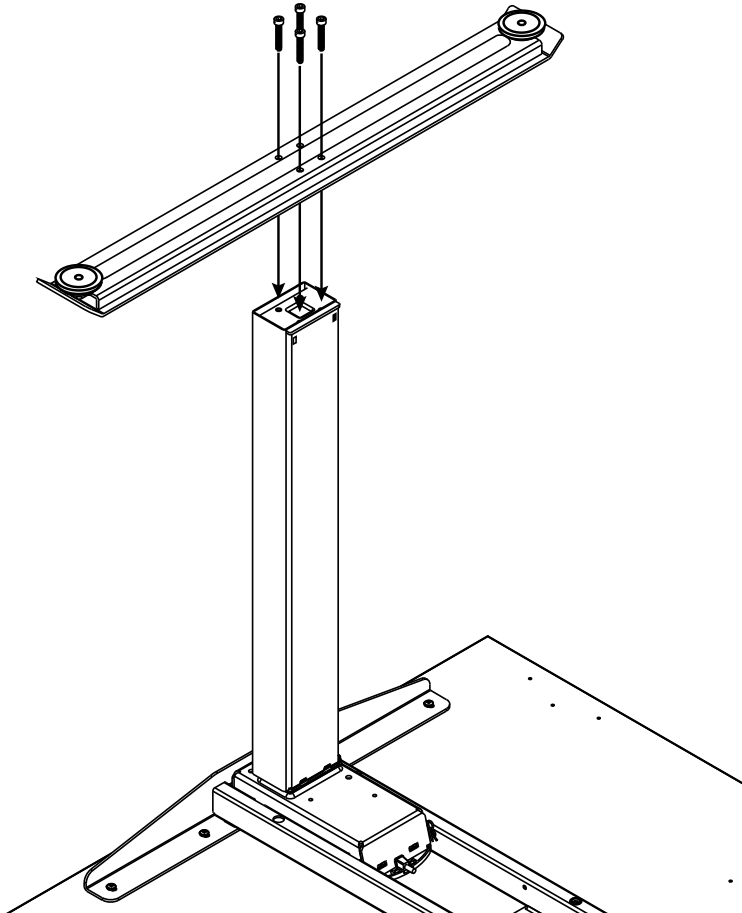

**1:1 HARDWARE**

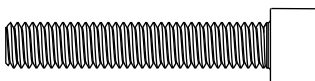

M6 x 35 mm Screws

**TOOLS**



5 mm Hex Key

**Step 8:** Attach the control box to the tabletop

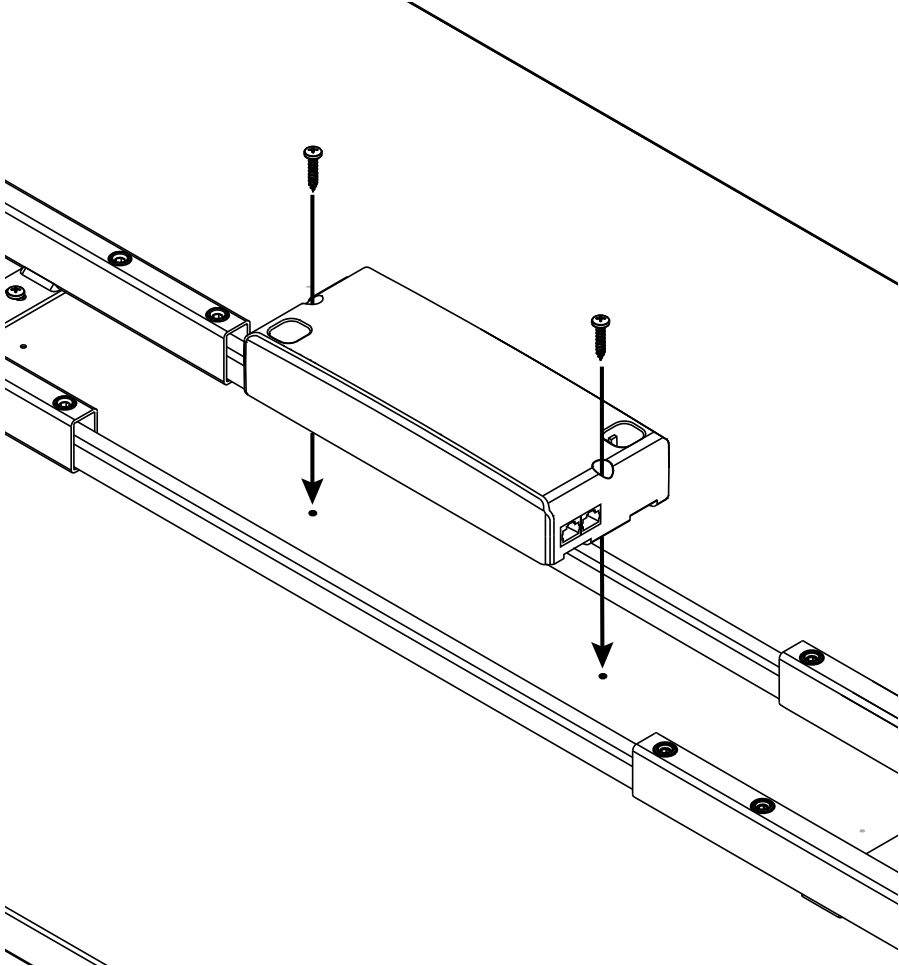

**1:1 HARDWARE**

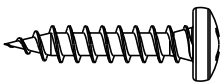

M5 x 25 mm Screw

**TOOLS**

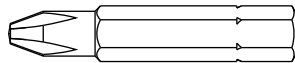

#2 Phillips Bit

**Step 9:** Attach the hand control to the tabletop.

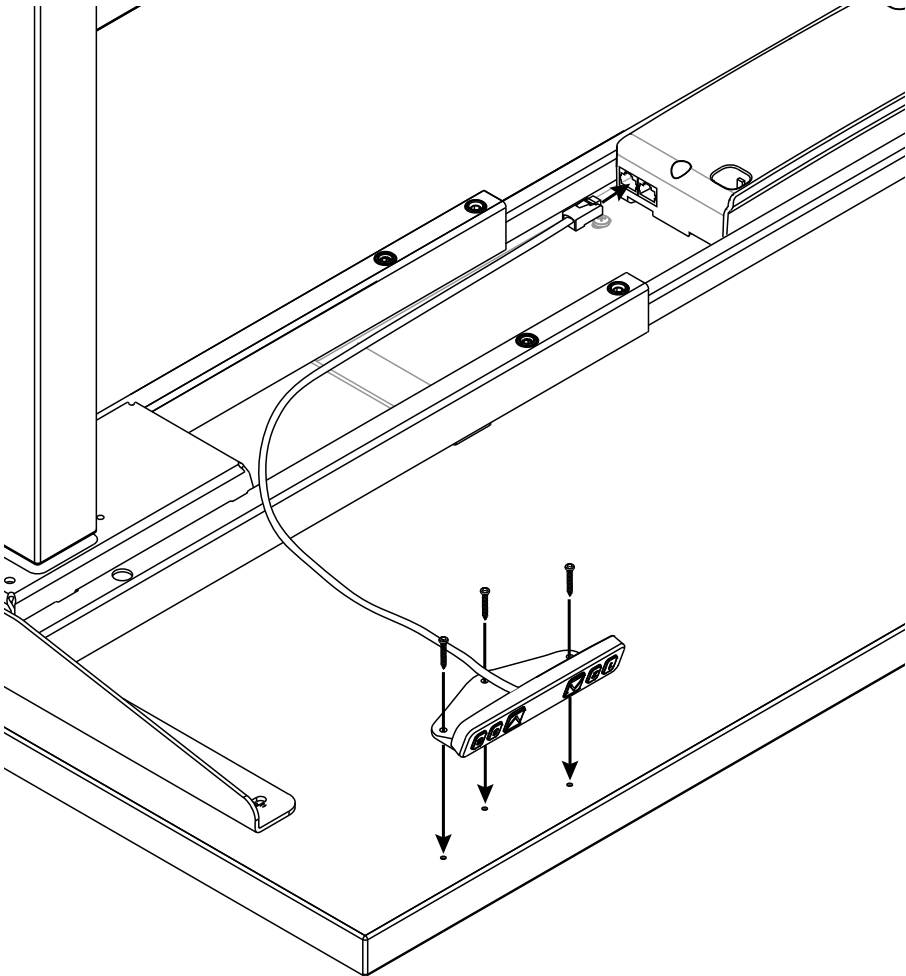

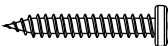
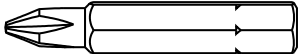
<p><b>1:1 HARDWARE</b></p>  <p>M3 x 20 mm Screw</p>	<p><b>TOOLS</b></p>  <p>#1 Phillips Bit</p>
--	--

# Surge

ASSEMBLY INSTRUCTIONS

**Step 10:** Route all cables from the columns to the control boxes, using the extension cables.

---

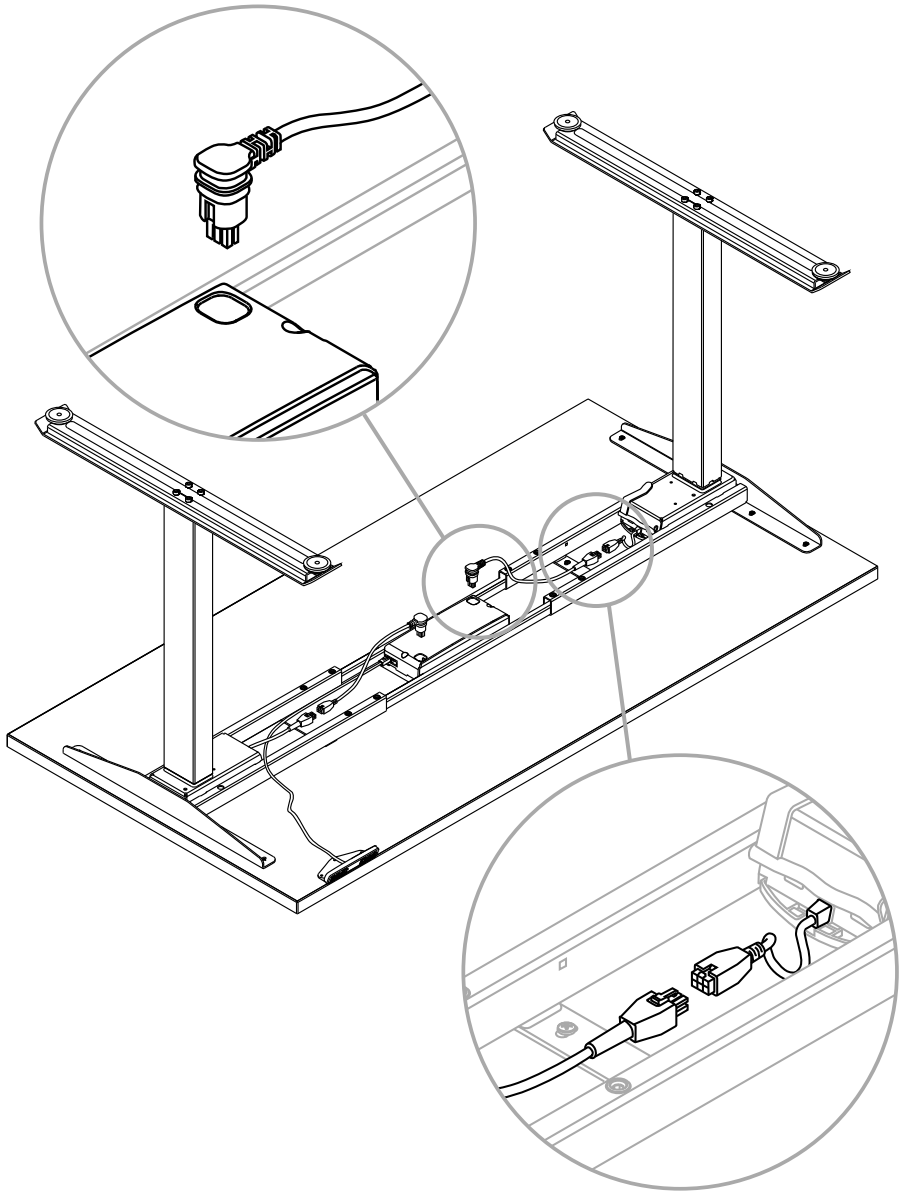

**Step 11 (Optional):** Use the wire clips and P-clips to manage cables.

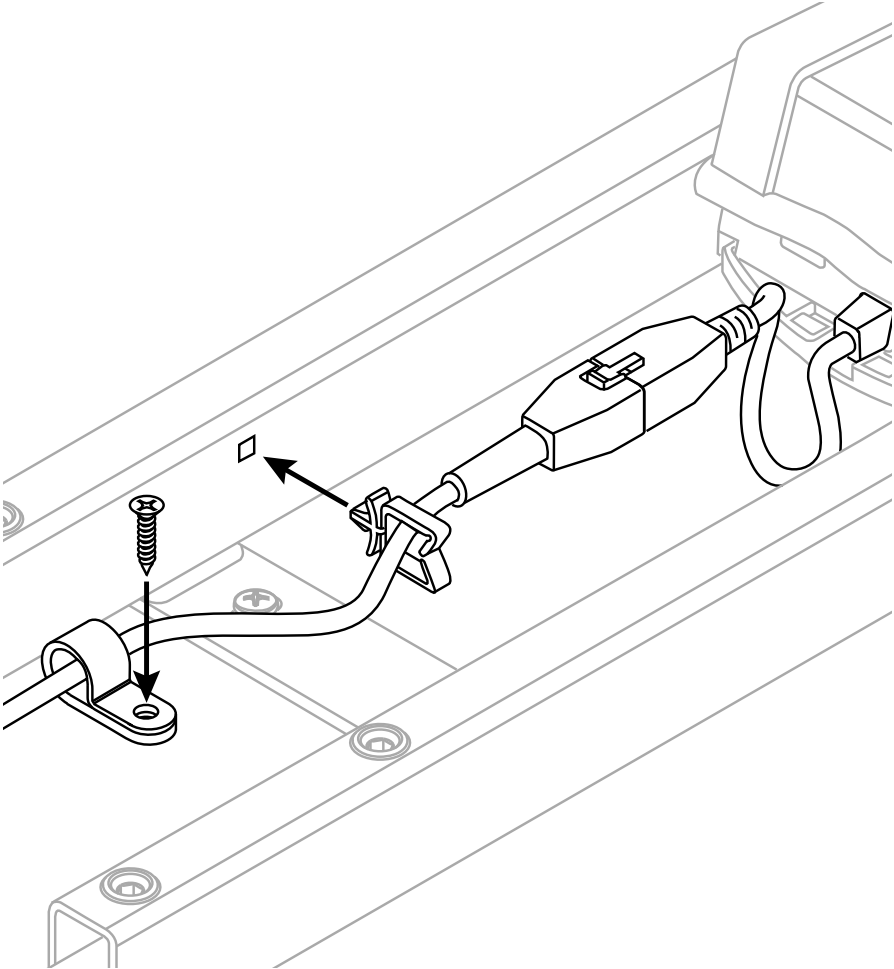

**1:1 HARDWARE**

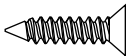

M3.5 x 16 mm Screw

**TOOLS**

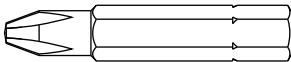

#2 Phillips Bit

**Step 12:** Turn the table upright and connect the A/C cable from the control box to the outlet.

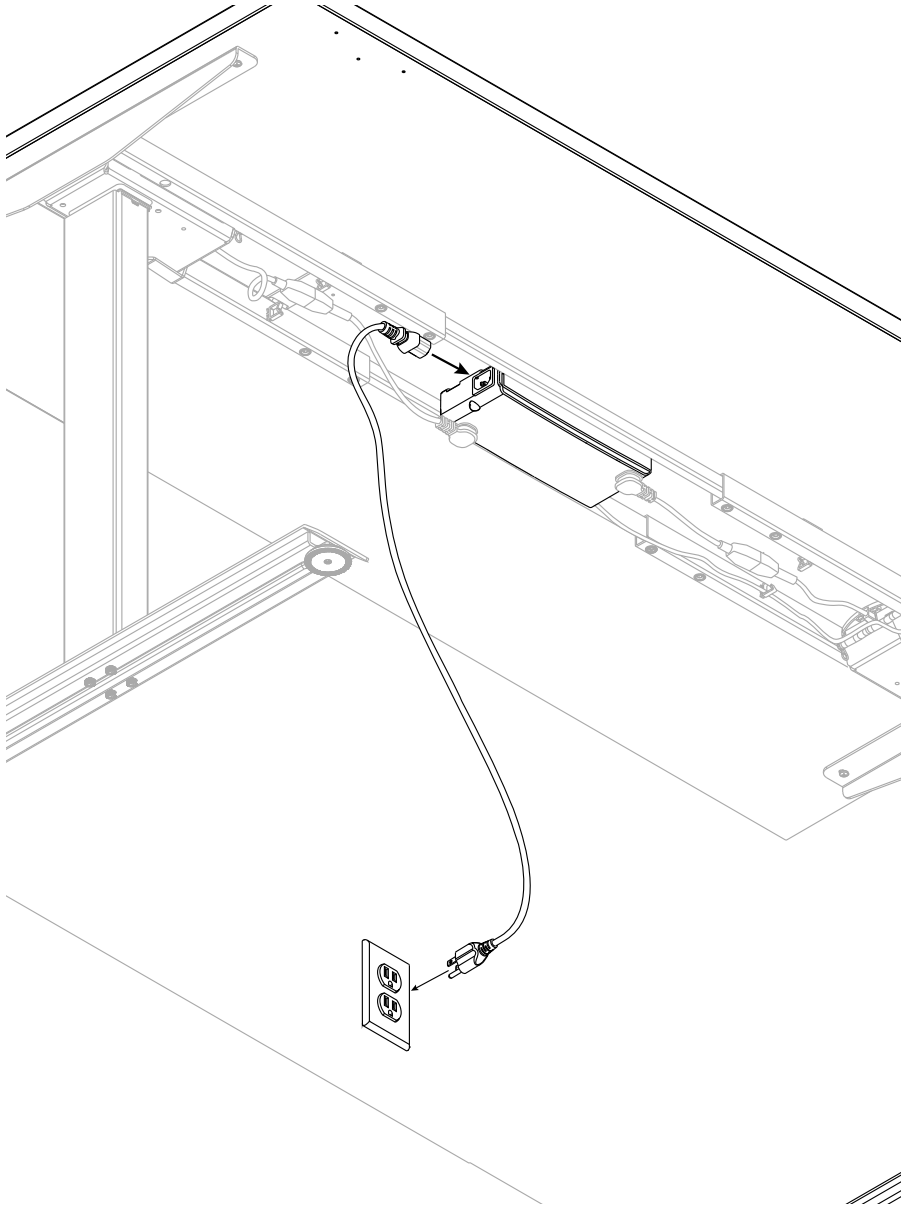

## Mounting Locations

If the height-adjustable base is being installed on a tabletop without pilot holes, reference the tables below to determine placement.

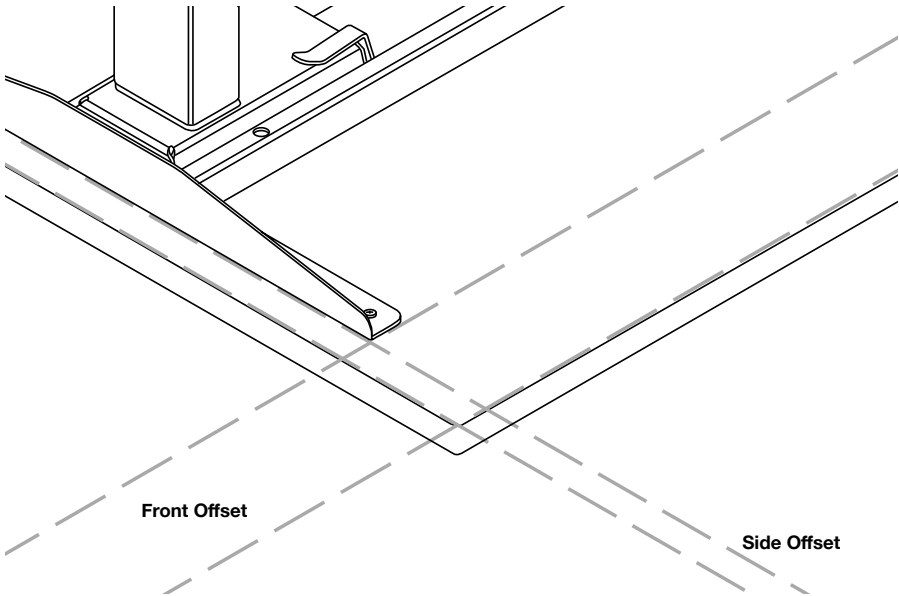

### Side Offset

Table Width	Offset
42"	N/A
44"-70"	1 1/8"
72"	1 3/4"
76"	4 1/8"
78"	4 3/4"
82"	7 1/8"
84"	7 3/4"
84"	7.38"

### Front Offset - Small Frames

Table Depth	Offset
23"	1.86"
24"	2.36"

### Front Offset - Large Frames

Table Depth	Offset
29"	4.2"
30"	4.7"



### Initialization

Check all cords to ensure they are fully connected. Initialization is recommended before using table and is the first step when troubleshooting issues.

1. Press the **▼** button until the table reaches its lowest position.
2. Simultaneously, press and hold both the **▲** and **▼** buttons. The legs will descend at half-speed of normal operation.
3. Continue holding the **▲** and **▼** buttons. The legs will move down to the lowest position and will 'rebound' slightly. The rebound indicates that the base is initialized.
4. Release the **▲** and **▼** buttons. Initialization is complete.

### Set Up the Memory Settings

1. Press and hold the **▲** or **▼** button to bring table to the desired height.
2. Press the **S** button, then press the **1**, **2** or **3** button. The current height of the table will be saved in the selected position.

### 1-Touch Memory Feature

1-Touch is enabled as default. The table will move to the programed height with a single press of each memory button.

The following steps allow this feature to be toggled on or off as desired.

When this feature is disabled each memory button must be held in until table reaches the programmed height.

1. Press and hold down the **S** button for 5-7 seconds until **---** appears on the digital screen. Let go of **S**.
2. Press and Release the **1** button. The screen will display **H-□**. 1-Touch is disabled.
3. Press the up **▲** button so the screen now reads **H-1**. 1-Touch is enabled
4. Press the **S** button until the screen readout returns to the digital height reading.

### Synchronize the Height Display

This feature allows user to recalibrate the height display so it matches the measured table height

1. Press and hold **S**. Then quickly press and hold the **Δ** button. Hold in both buttons until the display blinks.
2. Press the **Δ** or **∇** buttons to change the number to the desired number.
3. Repeat the above sequence to adjust each digit.
4. Press the **S** button to apply the settings.

### Set the Minimum Height

1. Press and hold the **∇** button until it reaches the desired position.
2. Press and hold the **S** button, then press and hold the **1** button. Do this for at least 3 seconds.
3. The letter **\_L\_** will appear on the screen indicating that the position is now “locked.”
4. Press the **S** button until the screen readout returns to the digital height reading.

### Set the Maximum Height

1. Press and hold the **Δ** button until it reaches the desired position.
2. Press and hold the **S** button, then press and hold the **3** button. Do this for at least 3 seconds.
3. The letter **~L~** will appear on the screen indicating that the position is now “locked.”
4. Press the **S** button until the screen readout returns to the digital height reading.

### To Clear Minimum and Maximum Height Settings

1. Press and hold the **S** button, then press and hold the **2** button. Do this for at least 3 seconds.
2. The letter **CL** will appear on the screen indicating the positions are clear.

**Trouble Shooting Steps**

Error Code	Description	Possible Solution
E01	Column Malfunction	Check the connecting cables between the column and control box. If the cable connectors or column receptacles are damaged, replace them.
E03	Overload	Remove weight from the tabletop.
E04	Data Exception	Control box functioning in a severe environment. Reinitialize the Height-Adjustable table.
E05	Key Stuck	Press the key several times to free it. Replace the handset.
E06	Communication Interrupted	Check the control box connectors. Unplug and replug-in the hand control.
E07	Table Height Was Set Incorrectly	Reset hand control height readout. Follow the steps on the following page.
E08	Motor Short Circuit	Replace any damaged cables and reinitialize.
E09	Signal Abnormal	Reinitialize the table.
E10	Drive Abnormal	Unplug from the power source and wait at least one minute for the control box to cool down. Plug it back in and reinitialize the table.
E11	Power Adapter Failure	Unplug from the power source and wait at least five minutes for the control box to cool down. Plug it back in and reinitialize the table.
E12	Gyro Sensor Malfunction	Unplug from the power source, replug in and reinitialize. Level the tabletop or place the control box on a horizontal surface.

**Handset Has Power but No Error Code?**

1. Check to see if the surface is level. Confirm that all legs are perpendicular, and that one leg is not at an angle after final placement of the table base. If the leg is bent (not straight) it may send a false signal to the control box.
2. Check to see if there is too much weight on the top of the table and remove excess weight
3. Check all cords to ensure they are fully connected
4. Check to ensure that there is no interference and that there are no items that can interfere with table movement.
5. Reinitialize using the steps on page 25.

### Reinitialize

Follow the same steps used during the initial setup on page 25 to reinitialize as a starting point to trouble-shooting.

### Reset Hand Control Readout

Error Code **E07** Indicates Height Display is incorrectly synchronized. The following steps move the table to lowest height and correct the Height Display value

1. Initialize the table using the steps on page 25. The table should be at its lowest point, typically with the top of the table at a height of 18.5".
2. Simultaneously press the **S** and **Δ** buttons for approximately 3 seconds. The first digit of the height readout should be blinking.
3. Press the **Δ** or **∇** button to set the first digit to eg. **1\_ \_**.
4. Press the **S** button. The middle number will start to blink.
5. Press the **Δ** or **∇** button to set the second digit to eg. **\_8\_**.
6. Press the **S** button. The third digit will begin to blink.
7. Press the **Δ** or **∇** button to set the third digit to eg. **\_ \_5**.
8. Press the **S** button one final time to apply the changes.